

Coolmay M3S PLC Programming Manual

Shenzhen Coolmay Technology Co., LTD

V22.91

Catalog

1. Overview	1
1.1 Advantages of COOLMAY M3S PLC:	1
1.2 M3S PLC specification	3
2. Soft element	4
2.1 Soft element table	4
3. Special relays and registers	6
3.1 Special relay number and content	6
3.2 Special register number and content	10
4. Function Instructions	13
4.1 List of basic logic instructions	13
4.2 Applied instructions 【Sequence is according to instruct variety】	14
5. Application of PID	20
5.1 PID Instruction	20
6. Application of high speed counter	25
6.1 Assignment table of built-in high speed counter	25
6.2 Related device	26
7. Application of high speed pulse output	28
7.1 high speed pulse output	28
7.2 Pulse width modulation (PWM)	29
8. Coolmay M3S PLC Communication Instructions	31
8.1 MODBUS instruction interpretation and communication address	31
8.1.1 RD3A/WR3A command function and action description:	31
8.1.2 ADPRW command function and action description	32
8.1.3 Word device Communication address number	33
8.1.4 Bit device Communication address number	34
8.1.5 ADPRW Command function parameter	34
8.2 Serial port 1: RS232(PLC programming port)	35
8.3 Serial port2:RS485(A B)/RS232	35
8.3.1 Mitsubishi programming port	37
8.3.2 Mitsubishi BD Agreement	37
8.3.3 Freeport protocol function and example	38

8.3.4 Modbus RTU Protocol	39
8.3.5 MODBUS RTU ADPRW command	42
8.3.6 Modbus ASCII Protocol	44
8.4 Serial port 3:RS485(A1 B1)	45
8.4.1 Mitsubishi programming protocol	48
8.4.2 Free port protocol function	48
8.4.3 Modbus RTU protocol RD3A/WR3A command	48
8.4.4 MODBUS RTU ADPRW Command	51
8.4.5 Modbus ASCII Function	52
8.5 Network N:N communication	53
8.5.1 Related device content	53
8.5.2 Program setting and description	56
Appendix Version Change Record	57



1. Overview

1.1 Advantages of COOLMAY M3S PLC:

- ◆ The programming software is compatible with GX Developer 8.86/GX Works2 (supports ladder diagram and SFC language, does not support structured programming, does not support the use of labels).
- ◆ Super function. Compatible with FX3S series PLC, fast running speed.
- ◆ Adopts military-grade 32-bit CPU, which is fast and is more suitable for industrial environments with high electromagnetic interference.
- ◆ Special encryption function prevents illegal reading. 8-bit encryption, the login keyword is set to 12345678, which can completely close the function of reading the ladder diagram program, thereby protecting the user's program.
- ◆ Comes with 2 PLC programming ports. M3S PLC comes with 1 Type-C port for faster download speed; 1 RS232 programming port, the interface terminal is an 8-hole mouse head female socket.
- ◆ Optional communication port, support Mitsubishi programming port protocol/MODBUS protocol/RS protocol, easily realize PLC interconnection and communication with external equipment such as HMI and inverter. M3S PLC defaults to 2 RS485 or change to 1 RS232, 1 RS485 communication interface.
- ◆ High-speed pulse output is generally 4 channels, Y0~Y1 each 100KHz, Y2~Y3 each 10KHz;
- ◆ High-speed counting is generally 2 single-phase 60KHz + 4 10KHz or 1 AB (Z) phase 30KHz + 1 AB (Z) phase 5KHz;
- ◆ M3S PLC digital is up to 24DI16DO; digital output type can choose transistor or relay and transistor mixed output.
- ◆ Convenient wiring, using fixed screw terminals. M3S series PLC terminals all use 5.00mm pitch screw terminals;

- ◆ Convenient installation. It can be installed on DIN rail (35mm wide) and fixing holes.
- ◆ Flexible use, more specifications and batches can be customized according to customer requirements.

1.2 M3S PLC specification

Model	M3S-24M	M3S-40M
Image		
Dimension	93*88*75mm	143*88*75mm
Cutout size	74*80mm	124*80mm
Installation method	Fixed hole installation and 35MM standard rail installation	
Digital points	14DI 10DO (MR up to 8, Y0/Y1 fixed MT)	24DI 16DO
Input and output level	Y0-Y3: Transistor output, and DC24V active NPN output; Other output MT: low level NPN, COM connected to negative; Output MR: normally open dry contact; Input: Passive NPN, common terminal isolation	
Do type and load	Relay MR/Transistor MT/Mixed output MRT The first 2 channels of Y0/Y1 of 24M are fixed as MT, and the output load is 0.1A/point; Other transistors MT output load 0.5A/point, 0.8A/4 points COM, 1.6A/8 points COM; Relay output load 2A/point, 4A/4 points COM, 5A/8 points COM, 5A/12 points COM.	
High-speed counting input	Conventional 2 single-phase 60KHz+4 10KHz or 1 AB(Z) phase 30KHz +1 AB(Z) phase 5KHz	
High-speed pulse output	Conventional 2-channels Y0-Y1 is 100KHz, Y2-Y3 is 10KHz; High-speed counting + high-speed pulse total can not exceed 300KHz	
COM port	Comes with two PLC programming ports (1 type-c port, faster download speed; 1 RS232 programming port, the interface terminal is an 8-hole mouse head female socket)	
	The default is 2 RS485; Or 1 RS232, 1 RS485 can be customized in batches	
Programming software	Compatible with GX Works2/GX Developer8.86Q	
Suggested model:	M3S-24MT/MRT(-485/485) M3S-40MT/MRT(-485/485)	
Detailed information reference:	《COOLMAY M3S PLC programming manual》 《COOLMAY M3S PLC User Manual》	

2. Soft element

2.1 Soft element table

Name	Contents		
I/O relay			
Input relay	X000~X025	24 points	Soft element number is octal Total 40 points for I/O
Output relay	Y000~Y017	16 points	
Auxiliary relay			
General	M0~M383	384 points	
EEPROM hold	M384~M511	128 points	
General	M512~M1535	1024 points	
Special	M8000~M8511	512 points	
Status			
Initial state (EEPROM hold)	S0~S9	10 points	
EEPROM hold	S10~S127	118 points	
General	S128~S255	128 points	
Timer (ON delay timer)			
100ms	T0~T31	32 points	0.1~3,276.7s
100ms/10ms*1	T32~T62	31 points	0.1~3,276.7s/0.01~327.67s After M8028 is turned ON, T32~T62 can be changed into 10ms timer
1ms	T63~T127	65 points	0.001~32.767s
1ms accumulative (EEPROM hold)	T128~T131	4 points	0.001~32.767s
100ms accumulative (EEPROM hold)	T132~T137	6 points	0.1~3,276.7s
Counter			
General up counter (16bit)	C0~C15	16 points	0~32,767 counter
EEPROM hold up counter (16 bit)	C16~C31	16 points	0~32,767 counter
General bi-direction (32 bit)	C200~C234	35 points	-2,147,483,648~+2,147,483,647 counter
High-speed counter			
Single-phase single counter input Bi-direction (32 bit) (EEPROM hold)	C235~C245	-2,147,483,648~+2,147,483,647 counter Software counter Single phase: up to 6 channels, Max frequency 60kHz Bi-phase: 1 times frequency: up to 2 channels, Max frequency 30kHz 4 times frequency: up to 2 channels, Max frequency 24kHz M8198 is the 4 times frequency logo of C251 M8199 is the 4 times frequency logo of C253	
Single-phase double counter input Bi-direction (32 bit) (EEPROM hold)	C246~C250		
Double-phase double counter input	C251~C255		

Bi-direction (32 bit)(EEPROM hold)			
Name	Contents		
Data register(32 bit when using in pair)			
General(16bit)	D0~D127 D256~D999	872 points	
EEPROM hold (16 bit)	D128~D255 D1000~D3999	3128 points	
General(16bit)	D256~D2999	2744 points	
Special (16 bit)	D8000~D8511	512 points	
Index (16 bit)	V0~V7,Z0~Z7	16 points	
Pointer			
JUMP、CALL branch	P0~P255	256 points	CJ instruct、CALL instruct
Input interrupt	I0□□~I5□□	6 points	
Timer interrupt	I6□□~I8□□	3 points	
Nest			
Master control	N0~N7	8 points	MC instruct
Constant			
Decimal (K)	16 bit	-32,768~+32,767	
	32 bit	-2,147,483,648~+2,147,483,647	
Hexadecimal (H)	16 bit	0000~FFFF	
	32 bit	00000000~FFFFFFFF	
Real number(E)*3	32 bit	-1.0×2 ¹²⁸ ~-1.0×2 ⁻¹²⁶ ,1.0×2 ⁻¹²⁶ ~1.0×2 ¹²⁸ Can be in the form of a decimal point and index	

※1: The 10ms timer will be affected by the scan cycle. If the scan period is 12ms, the timer becomes 12ms and is executed once.

3. Special relays and registers

3.1 Special relay number and content

No.	Content	Remarks	No.	Content	Remarks
M8000	In RUN, Normally closed		M8216	C216 Increase/decrease counting action	ON:decrease action OFF:increase action
M8001	In RUN, Normally open		M8217	C217 Increase/decrease counting action	
M8002	After RUN, Output a scan cycle ON		M8218	C218 Increase/decrease counting action	
M8003	After RUN, Output a scan cycle OFF		M8219	C219 Increase/decrease counting action	
M8011	Oscillating in 10ms cycle		M8220	C220 Increase/decrease counting action	
M8012	Oscillating in 100ms cycle		M8221	C221 Increase/decrease counting action	
M8013	Oscillating in 1s cycle		M8222	C222 Increase/decrease counting action	
M8014	Oscillating in 1min cycle		M8223	C223 Increase/decrease counting action	
M8020	Zero flag		M8224	C224 Increase/decrease counting action	
M8021	Borrowing flag		M8225	C225 Increase/decrease counting action	
M8022	Carry flag		M8226	C226 Increase/decrease counting action	
M8024	Specify BMOV direction		M8227	C227 Increase/decrease counting action	
M8028	During instruction execution, allow interrupt		M8229	Handwheel function enablement	
M8029	Instruction execution end flag		M8230	C229 Increase/decrease counting action	
M8031	Non-retentive memory is cleared		M8231	C230 Increase/decrease counting action	
M8032	Retentive memory is cleared		M8232	C231 Increase/decrease counting action	
M8033	Memory retention stop		M8233	C232 Increase/decrease counting action	
M8034	Prohibit all output		M8234	C233 Increase/decrease counting action	
M8035	Forced RUN mode		M8235	C234 Increase/decrease counting action	

No.	Content	Remarks	No.	Content	Remarks
M8036	Force RUN command		M8236	C235 Increase/decrease counting action	OFF:increase action
M8037	Force STOP command		M8237	C236 Increase/decrease counting action	
M8045	Prohibit reset of all outputs		M8238	C237 Increase/decrease counting action	
M8046	STL state action		M8239	C238 Increase/decrease counting action	
M8047	STL temporary control is effective		M8240	C239 Increase/decrease counting action	
M8048	Signal alarm action		M8241	C240 Increase/decrease counting action	
M8049	Signal alarm is effective		M8242	C241 Increase/decrease counting action	
M8050	Input interrupt(I00 □ Prohibited)		M8243	C242 Increase/decrease counting action	
M8051	Input interrupt(I10 □ Prohibited)		M8244	C244 Increase/decrease counting action	
M8052	Input interrupt(I20 □ Prohibited)		M8245	C245 Increase/decrease counting action	ON:decrease action OFF:increase action
M8053	Input interrupt(I30 □ Prohibited)		M8246	C246 Increase/decrease counting action	
M8054	Input interrupt(I40 □ Prohibited)		M8247	C247 Increase/decrease counting action	
M8055	Input interrupt(I50 □ Prohibited)		M8248	C248 Increase/decrease counting action	
M8056	Timer interrupt(I6 □ □ Prohibited)		M8249	C249 Increase/decrease counting action	
M8057	Timer interrupt(I7 □ □ Prohibited)		M8250	C250 Increase/decrease counting action	
M8058	Timer interrupt(I8 □ □ Prohibited)		M8251	C251 Increase/decrease counting action	
M8060	I/O Constitute error		M8252	C252 Increase/decrease counting action	
M8061	PLC hardware error		M8253	C253 Increase/decrease counting action	
M8062	Serial communication error 0		M8254	C254 Increase/decrease counting action	
M8063	Serial communication error 1		M8255	C255 Increase/decrease counting action	
M8064	Parameter error		M8340	1 st pulse operation temporary control	

No.	Content	Remarks	No.	Content	Remarks
M8065	Grammatical error		M8341	Y000 clear signal output function is valid	
M8066	Loop error		M8342	Y000 specify the origin return direction	
M8067	Operation error		M8343	Y000 forward limit	
M8068	Operation error latch		M8344	Y000 reverse limit	
M8069	I/O bus detection		M8345	Y000 near-point DOG signal logic inversion	
M8075	Sample tracking preparation start command		M8346	Y000 zero signal logic inversion	
M8076	Sample tracking execution start command		M8347	Y000 interrupt signal logic inversion	
M8077	Sampling and tracking execution temporary control		M8348	Y000 positioning command driver	
M8078	Sample tracking execution end temporary control		M8349	1 st pulse stop	
M8079	Sampling tracking system area		M8350	2 nd pulse operation temporary control	
M8121	RS/RS2 command sends standby		M8351	Y001 clear signal output function is valid	
M8122	RS/RS2 command to send request		M8352	Y001 specify the origin return direction	
M8123	RS/RS2 command reception end		M8353	Y001 forward limit	
M8124	RS/RS2 command data in reception		M8354	Y001 reverse limit	
M8125	MODBUS and Mitsubishi function enablement		M8355	Y001 near-point DOG signal logic inversion	
M8128	RD3A/WR3A Receive correct		M8356	Y001 zero signal logic inversion	
M8129	RD3A/WR3A communication timeout		M8357	Y001 interrupt signal logic inversion	
M8160	XCH's SWAP function		M8358	Y001 positioning command driver	
M8161	8-bit processing mode		M8359	2 nd pulse stop	
M8170	Input X000 pulse capture		M8360	3 rd pulse operation temporary control	
M8171	Input X001 pulse capture		M8361	Y002 clear signal output function is valid	
M8172	Input X002 pulse capture		M8362	Y002 specify the origin return direction	
M8173	Input X003 pulse capture		M8363	Y002 forward limit	
M8174	Input X004 pulse capture		M8364	Y002 reverse limit	
M8175	Input X005 pulse capture		M8365	Y002 near-point DOG signal	

No.	Content	Remarks	No.	Content	Remarks
				logic inversion	
M8176	Input X006 pulse capture		M8366	Y002 zero signal logic inversion	
M8177	Input X007 pulse capture		M8367	Y002 interrupt signal logic inversion	
M8192	Programming port protocol and other protocol enablement	Serial port 3	M8368	Y002 positioning command driver	
M8196	Programming port protocol and other protocol enablement	Serial port 2	M8369	3 rd pulse stop	
M8198	4 times frequency of C251/C252		M8370	4 th pulse operation temporary control	
M8199	4 times frequency of C253		M8371	Y003 clear signal output function is valid	
M8200	C200 Increase/decrease counting action	ON:decrease action OFF:increase action	M8372	Y003 specify the origin return direction	
M8201	C201 Increase/decrease counting action		M8373	Y003 forward limit	
M8202	C202 Increase/decrease counting action		M8374	Y003 forward limit	
M8203	C203 Increase/decrease counting action		M8375	Y003 near-point DOG signal logic inversion	
M8204	C204 Increase/decrease counting action		M8376	Y003 zero signal logic inversion	
M8205	C205 Increase/decrease counting action		M8377	Y003 interrupt signal logic inversion	
M8206	C206 Increase/decrease counting action		M8378	Y003 positioning command driver	
M8207	C207 Increase/decrease counting action		M8379	4th pulse stop	
M8208	C208 Increase/decrease counting action		M8396	C254 function corresponds to input phase	
M8209	C209 Increase/decrease counting action		M8401	RS2 command sends standby	
M8210	C210 Increase/decrease counting action		M8402	RS2 command to send request	
M8211	C211 Increase/decrease counting action		M8403	RS2 command reception end	
M8212	C212 Increase/decrease counting action		M8404	RS2 command data in reception	
M8213	C213 Increase/decrease counting action		M8405	RS2 command data setting ready	
M8214	C214 Increase/decrease counting action		M8408	RD3A/WR3A Receive Completed	

No.	Content	Remarks	No.	Content	Remarks
M8215	C215 Increase/decrease counting action		M8409	RD3A/WR3A communication timeout	

3.2 Special register number and content

No.	Content	Remarks	No.	Content	Remarks
D8000	Watchdog timer		D8189	V4 Register contents	
D8001	PLC type and system version	Main version number	D8190	Z5 Register contents	
D8002	PLC memory capacity	2...2K steps 4...4K steps 8...8K steps	D8191	V5 Register contents	
D8003	Memory type	10H:Programmable controller built-in memory	D8192	Z6 Register contents	
D8010	Scan current value		D8193	V6 Register contents	
D8011	Scan time minimum		D8194	Z7 Register contents	
D8012	Scan time maximum		D8195	V7 Register contents	
D8013	Second		D8268	Customize PWM 0~1 division factor	Low
D8014	Minute		D8269		High
D8015	Hour		D8340	1 st position pulse amount	Low
D8016	Date		D8341		High
D8017	Month		D8342	Y0 deviation speed Initial value:0	
D8018	Year		D8343	1 st pulse maximum speed	Low
D8019	Week		D8344		High
D8020	Input filter adjustment		D8345	Y0 crawling speed Initial value: 1000	
D8030	AD0 analog input value		D8346	Y0 Origin return speed	Low
D8031	AD1 analog input value		D8347	Initial value:50000	High
D8059	Constant scan time		D8348	1 st pulse acceleration time	
D8074	X0 Rising edge ring counter value [1/6μs unit]	Low	D8349	1 st pulse deceleration time	
D8075		High	D8350	2 nd position pulse amount	Low
D8076	X0 falling edge ring counter value [1/6μs unit]	Low	D8351		High
D8077		High	D8352	Y1 deviation speed Initial value:0	
D8078	X0 pulse width / pulse period [10μs unit]	Low	D8353	2 nd pulse maximum speed	Low
D8079		High	D8354		High
D8080	X1 Rising edge ring counter value [1/6μs unit]	Low	D8355	Y1 crawling speed Initial value: 1000	
D8081		High	D8356	Y1 Origin return speed	Low

No.	Content	Remarks	No.	Content	Remarks
D8082	X1 falling edge ring counter value	Low	D8357	Initial value:50000	High
D8083	[1/6μs unit]	High	D8358	2 nd pulse acceleration time	
D8084	X1 pulse width / pulse period	Low	D8359	2 nd pulse deceleration time	
D8085	[10μs unit]	High	D8360	3 rd position pulse amount	Low
D8086	X3 Rising edge ring counter value	Low	D8361		High
D8087		[1/6μs unit]	High	D8362	Y2 deviation speed Initial value:0
D8088	X3 falling edge ring counter value	Low	D8363	3 rd pulse maximum speed	Low
D8089	[1/6μs unit]	High	D8364		High
D8090	X3 pulse width / pulse period	Low	D8365	Y2 crawling speed Initial value: 1000	
D8091	[10μs unit]	High	D8366	Y2 Origin return speed	Low
D8092	X4 Rising edge ring counter value	Low	D8367	Initial value:50000	High
D8093		[1/6μs unit]	High	D8368	3 rd pulse acceleration time
D8094	X4 falling edge ring counter value	Low	D8369	3 rd pulse deceleration time	
D8095	[1/6μs unit]	High	D8370	4 th position pulse amount	Low
D8096	X4 pulse width / pulse period	Low	D8371		High
D8097		[10μs unit]	High	D8372	Y3 deviation speed Initial value:0
D8101	PLC type and system version		D8373	4 th pulse maximum speed	Low
D8102	PLC memory capacity		D8374		High
D8108	Number of special modules connected		D8375	Y3 crawling speed Initial value:1000	
D8109	Y number of output refresh error		D8376	Y3 Origin return speed	Low
D8120	Modbus RTU protocol Communication parameters		D8377		Initial value:50000
D8121	Master and slave station number		D8378	4 th pulse acceleration time	
D8122	RS command to send data remaining points		D8379	4 th pulse deceleration time	
D8123	RS command to receive points monitoring				
D8124	RS header <initial value: STX>		D8397	ADPRW command serial port position	
D8125	RS trailer <initial value: ETX>		D8398	0~2147483647(1ms) Ring count for incremental actions	
D8126	When the serial port 2 uses the ADPRW command, the value is 0.		D8399		
D8127	Serial port 2 interval period number		D8400	Modbus RTU protocol Communication parameters	
D8128	Specify the starting number of the communication request of the lower		D8401	Communication mode	

No.	Content	Remarks	No.	Content	Remarks
	computer				
D8129	Specify the number of data requested by the lower computer communication		D8406	Number of intervals	
D8169	Restrict access status		D8409	Overtime time	
D8182	Z1 Register contents		D8410	RS2 header 1, 2 <initial value: STX>	
D8183	V1 Register contents		D8411	RS2 header 3, 4	
D8184	Z2 Register contents		D8412	RS2 trailer 1, 2 <initial value: ETX>	
D8185	V2 Register contents		D8413	RS2 trailer 3, 4	
D8186	Z3 Register contents		D8414	Master and slave station number	
D8187	V3 Register contents		D8415	RS2 receives the summation calculation result	
D8188	Z4 Register contents		D8416	RS2 sends summation	

For detailed functions, please refer to "[Coolmay PLC Instruction Programming Manual](#)".

4. Function Instructions

4.1 List of basic logic instructions

Mnemonic	Name	Features	Available devices
LD	take	Normally open contact logic operation starts	X,Y,M,S,D□.b,T,C
LDI	Negate	Normally closed contact logic operation starts	X,Y,M,S,D□.b,T,C
LDP	Take the rising edge of the pulse	Start of operation to detect rising edge	X,Y,M,S,D□.b,T,C
LDF	Take the falling edge of the pulse	Start of operation to detect falling edge	X,Y,M,S,D□.b,T,C
AND	versus	Series of normally open contacts	X,Y,M,S,D□.b,T,C
ANI	With reverse	Series of normally closed contacts	X,Y,M,S,D□.b,T,C
ANDP	With pulse rising edge	Detect rising edge series connection	X,Y,M,S,D□.b,T,C
ANDF	With the falling edge of the pulse	Series connection detection of falling edges	X,Y,M,S,D□.b,T,C
OR	Or pulse rising edge	Normally open contacts in parallel	X,Y,M,S,D□.b,T,C
ORI	Or reverse	Normally closed contacts in parallel	X,Y,M,S,D□.b,T,C
ORP	Or pulse rising edge	Parallel connection detecting rising edge	X,Y,M,S,D□.b,T,C
ORF	Or pulse falling edge	Parallel connection to detect falling edge	X,Y,M,S,D□.b,T,C
ANB	Block with	Series connection of circuit blocks	-
ORB	Block or	Parallel connection of circuit blocks	-
MPS	Push stack	Push onto the stack	-
MRD	Read stack	Read stack	-
MPP	Unstack	Pop the stack	-
INV	Negate	Inversion of operation result	-
MEP	M.E.P	Conduction on rising edge	-
MEF	M..EF	Conduction on falling edge	-
OUT	Output	Coil drive	Y,M,S,D□.b,T,C
SET	Position	Movement retention	Y,M,S,D□.b
RST	Reset	Clear action keeps, register cleared	Y,M,S,D□.b,T,C, D,R,V,Z
PLS	pulse	Differential output on rising edge	Y,M
PLF	Falling edge pulse	Differential output on falling edge	Y,M
MC	Master	Connection circle command for common series point	Y,M
MCR	Master reset	Instruction to eliminate common series point	-
NOP	No operation	No action	-
END	End	End of the program and I/O and return to the beginning	-

4.2 Applied instructions 【Sequence is according to instruct variety】

(Command comparison table with Mitsubishi FX3S/FX3G PLC)

Applied instruction can be divided into the following 18 kinds.

1	Data move instructions
2	Data conversion instructions
3	Comparison instructions
4	Arithmetic operation instructions
5	Logical operation instructions
6	Special function instructions
7	Rotate instructions
8	Data operation instructions
9	Data operation instructions
10	Character string operation instructions
11	Program flow control instructions
12	I/O refresh instructions
13	Real time clock control instructions
14	Pulse output/positioning control instructions
15	Serial communication
16	Special block/unit control instructions
17	Other handy instruct

1. Data move instructions

Mnemonic	FNC No.	Function	Support
MOV	12	Move	★
SMOV	13	Shift Move	★
CML	14	Compliment	★
BMOV	15	Block Move	★
FMOV	16	Fill Move	★
PRUN	81	Parallel Run (Octal Mode)	★
EMOV	112	Floating Point Move	★

2. Data conversion instructions

Mnemonic	FNC No.	Function	Support
BCD	18	Conversion to Binary Coded Decimal	★
BIN	19	Conversion to Binary	★
GRY	170	Decimal to Gray Code Conversion	★
GBIN	171	Gray Code to Decimal Conversion	★
FLT	49	Conversion to Floating Point	★
INT	129	Floating Point to Integer Conversion	★

3. Comparison instructions

Mnemonic	FNC No.	Function	Support
LD=	224	Contact compare LD (S1)=(S2)	★
LD>	225	Contact compare LD (S1)>(S2)	★
LD<	226	Contact compare LD (S1)<(S2)	★
LD<>	228	Contact compare LD (S1)≠(S2)	★
LD<=	229	Contact compare LD (S1)≧(S2)	★
LD>=	230	Contact compare LD (S1)≦(S2)	★
AND=	232	Contact compare AND (S1)=(S2)	★
AND>	233	Contact compare AND (S1)>(S2)	★
AND<	234	Contact compare AND (S1)<(S2)	★
AND<>	236	Contact compare AND (S1)≠(S2)	★
AND<=	237	Contact compare AND (S1)≧(S2)	★
AND>=	238	Contact compare AND (S1)≦(S2)	★
OR=	240	Contact compare OR (S1)=(S2)	★
OR>	241	Contact compare OR (S1)>(S2)	★
OR<	242	Contact compare OR (S1)<(S2)	★
OR<>	244	Contact compare OR (S1)≠(S2)	★
OR<=	245	Contact compare OR (S1)≧(S2)	★
OR>=	246	Contact compare OR (S1)≦(S2)	★
CMP	10	Compare	★
ZCP	11	Zone Compare	★
ECMP	110	Floating Point Compare	★
HSCS	53	High speed counter set	★
HSCR	54	High speed counter reset	★
HSZ	55	High Speed Counter Zone Compare	★

4. Arithmetic operation instructions

Mnemonic	FNC No.	Function	Support
ADD	20	Addition	★
SUB	21	Subtraction	★
MUL	22	Multiplication	★
DIV	23	Division	★
EADD	120	Floating Point Addition	★
ESUB	121	Floating Point Subtraction	★
EMUL	122	Floating Point Multiplication	★
EDIV	123	Floating Point Division	★
INC	24	Increase	★

DEC	25	Decrement	★
-----	----	-----------	---

5. Logical operation instructions

Mnemonic	FNC No.	Function	Support
WAND	26	Word AND	★
WOR	27	Word OR	★
WXOR	28	Word Exclusive OR	★

6. Special function instructions

Mnemonic	FNC No.	Function	Support
ESQR	127	Floating Point Square Root	★

7. Rotate instructions

Mnemonic	FNC No.	Function	Support
ROR	30	Rotation Right	★
ROL	31	Rotation Left	★

8. Shift instructions

Mnemonic	FNC No.	Function	Support
SFTR	34	Bit Shift Right	★
SFTL	35	Bit Shift Left	★
WSFR	36	Word Shift Right	★
WSFL	37	Word Shift left	★
SFWR	38	Shift Write [FIFO/FILO Control]	★
SFRD	39	Shift Read [FIFO Control]	★

9. Data operation instructions

Mnemonic	FNC No.	Function	Support
ZRST	40	Zone Reset	★
DECO	41	Decode	★
ENCO	42	Encode	★
MEAN	45	Mean	★
SUM	43	Sum of Active Bits	★
BON	44	Check Specified Bit Status	★
CCD	84	Check Code	★

SER	61	Search a Data Stack	★
-----	----	---------------------	---

10. String processing instruction

Mnemonic	FNC No.	Function	Support
ASCI	82	Hexadecimal to ASCII Conversion	★
HEX	83	ASCII to Hexadecimal Conversion	★

11. Program flow control instructions

Mnemonic	FNC No.	Function	Support
CJ	00	Conditional Jump	★
CALL	01	Call Subroutine	★
SRET	02	Subroutine Return	★
IRET	03	Interrupt Return	★
EI	04	Enable Interrupt	★
DI	05	Disable Interrupt	★
FEND	06	Main Routine Program End	★
FOR	08	Start a FOR/NEXT Loop	★
NEXT	09	End a FOR/NEXT Loop	★

12. I/O refresh instructions

Mnemonic	FNC No.	Function	Support
REF	50	Refresh	★
REFF	51	Refresh and Filter Adjust	★

13. Real time clock control instructions

Mnemonic	FNC No.	Function	Support
TCMP	160	RTC Data Compare	★
TZCP	161	RTC Data Zone Compare	★
TADD	162	RTC Data Addition	★
TSUB	163	RTC Data Subtraction	★
TRD	166	Read RTC data	★
TWR	167	Set RTC data	★

14. Pulse output/positioning control instruction

Mnemonic	FNC	Function	Support
----------	-----	----------	---------

	No.		
ABS	155	Absolute Current Value Read	★
DSZR	150	DOG Search Zero Return	★
ZRN	156	Zero Return	★
TBL	152	Batch Data Positioning Mode	★
DRVI	158	Drive to Increment	★
DRVA	159	Drive to Absolute	★
PLSV	157	Variable Speed Pulse Output	★
PLSY	57	Pulse Y Output	★
PLSR	59	Acceleration/Deceleration Setup	★

15. Serial communication instructions

Mnemonic	FNC No.	Function	Support
RS	80	Serial Communication	★
R(S2)	87	Serial Communication 2	★
ADPRW	276	MODBUS read and write	★

16. Special block/unit control instructions

Mnemonic	FNC No.	Function	Support
FROM	78	Read From a Special Function Block	★
TO	79	Write To a Special Function Block	★
RD3A	176	Read form Dedicated Analog Block	★
WR3A	177	Write to Dedicated Analog Block	★
RBFM	278	Divided BFM Read	
WBFM	279	Divided BFM Write	

17. Other handy instructions

Mnemonic	FNC No.	Function	Support
WDT	07	Watchdog Timer Refresh	★
ALT	66	Alternate State	★
ANS	46	Timed Annunciator Set	★
ANR	47	Annunciator Reset	★
HOUR	169	Hour Meter	★
RAMP	67	Ramp Variable Value	★
SPD	56	Speed Detection	★
PWM	58	Pulse Width Modulation	★
PID	88	PID Control Loop	★

ABSD	62	Absolute Drum Sequencer	★
INCD	63	Incremental Drum Sequencer	★
IST	60	Initial state	★
MTR	52	Input Matrix	★
DSW	72	Digital switch (thumbwheel input)	★
SEGL	74	Seven Segment With Latch	★
VRRD	85	Volume Read	★
VRSC	86	Volume Scale	★

5. Application of PID

5.1 PID Instruction

1. Outline

This command is used to perform PID control that changes the output value according to the amount of change in the input.

2. PID instruction format and parameter description

Instruction format:

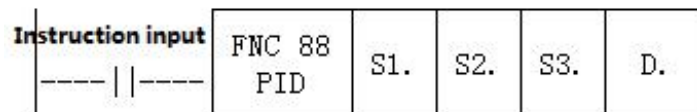

Parameter Description:

Operand Type	Content	Data Type	Word software component
S1.	Save data register number of the target value (SV)	BIN16 bit	D,R
S2.	Save data register number of the measured value (PV)	BIN16 bit	D,R
S3.	Save the data register number of the parameter	BIN16 bit	D,R
D.	Save data register number of the output register (MV)	BIN16 bit	D,R

3. Function and action description

16-bit operation (PID): After setting the target value S1., the measured value S2., and the parameters S3~S3+6 in the execution program, the operation result (MV) is saved to the output value D. every sampling time S3.

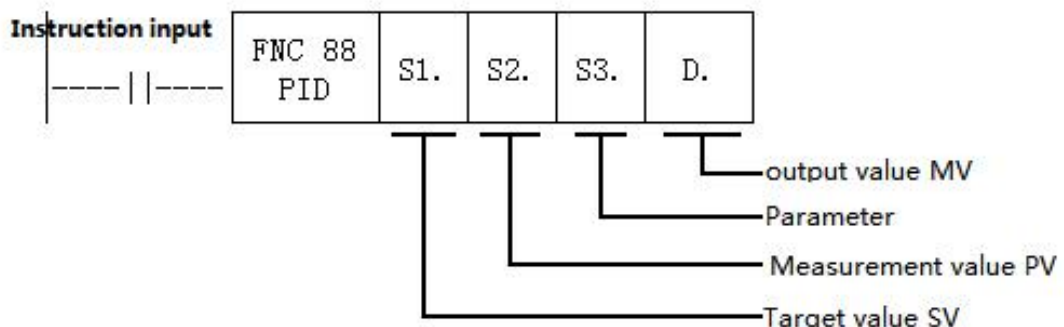

Setting item

Setting item	Content	Occupied points
--------------	---------	-----------------

1.	S Target value(SV)	Set target value (SV) PID instruction does not change the setting contents	1 point
2.	S Measured value(PV)	The input value of the PID operation	1 point
3.	S Parameter	Auto-tuning: step response method a) ACT setting: when bit1,bit2,bit5 are all not "0",occupy 25points Soft Component starting from the Initial Soft Component specified in S3. b) ACT setting: when bit1,bit2,bit5 are all "0",occupy 20points Soft Component starting from the Initial Soft Component specified in S3.	25 points 20 points
.	D Output value (MV)	Auto-tuning: step response method Set the step output value on the user side before the instruction is driven. During the auto-tuning process, the MV output cannot be changed on the side of the PID instruction.	1 point

Parameter list S3.~S3.+28

Setting item		Setting content	Remark	
S3.	Sampling time(Ts)	1~32767(ms)	Value shorter than the calculation period can't be run	
S3.+1	ACT	bit0	0: positive action; 1: reverse action.	Action direction (ACT)
		bit1	0: No input change alarm; 1: Input change amount alarm is valid.	
		bit2	0: No output change alarm; 1: Output change amount alarm is valid.	Do not turn ON bit2 and bit5 at the same time
		bit3	Can't use	
		bit4	0: Auto-tuning doesn't work; 1: Perform auto-tuning.	
		bit5	0: No output value upper and lower limit setting; 1: The output value upper and lower limits are valid.	Do not turn ON bit2 and bit5 at the same time
		bit6	0: Step response method.	Auto-tuning mode
		bit7~bit15	Can't use	
S3.+2	Input filter constant (α)	0~99(%)	0 means no input filtering	
S3.+3	Proportional gain ()	1~32767(%)		
S3.+4	Integration time()	0~32767(*100ms)	0 means as ∞ processing (no points)	
S3.+5	Differential gain ()	0~100(%)	0 means no derivative gain	
S3.+6	Derivative time ()	0~32767(*10ms)	0 means no differential processing	
S3.+7 ... S3.+19	PID operation internal processing occupied, please do not change the data.			
S3.+20 *1	Input change amount (increase side) alarm set value	0~32767	(ACT): Valid when S3.+1 bit1=1	
S3.+21 *1	Input change amount (decrease side) alarm set value	0~32767	(ACT): Valid when S3.+1 bit1=1	
S3.+22 *1	Output change amount (increase side) alarm set value	0~32767	(ACT): Valid when S3.+1 bit2=1, bit5=0	
	Output upper limit set value	-32768~32767	(ACT): Valid when S3.+1 bit2=0, bit5=1	
S3.+23 *1	Output change amount (decrease side) alarm set value	0~32767	(ACT): Valid when S3.+1 bit2=1, bit5=0	

	Output lower limit set value	-32768~32767	(ACT): Valid when S3.+1 bit2=0, bit5=1	
S3.+24 *1	Alarm output	bit0	0: The input change amount (increase side) does not overflow; 1: Input change amount (increase side) overflow.	(ACT): Valid when S3.+1 bit1=1 or bit2=1
		bit1	0: The input change amount (reduction side) does not overflow; 1: Input change amount (reduction side) overflow.	
		bit2	0: The output change amount (increase side) does not overflow; 1: Output change amount (increase side) overflow.	
		bit3	0: The output change amount (reduction side) does not overflow; 1: Output change amount (reduction side) overflow.	

*1: When S3+1 action setting (ACT) bit1=1, bit2=1 or bit5=1, S3+20~24 is occupied.

4. Notice

When using multiple instructions: It can be executed multiple times at the same time (the number of loops is not limited), but note that the S3 and D devices used in the operation cannot be repeated.

Occupied points of parameter S3.: Step response method

1) ACT setting: when bit1,bit2,bit5 are all not "0",occupy 25points Soft Component starting from the Initial Soft Component specified in S3.

2) ACT setting: when bit1,bit2,bit5 are all "0",occupy 20points Soft Component starting from the Initial Soft Component specified in S3.

Step response mode: The self-tuning mode in the PID instruction has only a step response mode, and the step value is S0+22, which is the upper limit value.

When specifying the soft component in the power failure holding area: If D. is specified in the program to hold the data register in the power failure,

needs to clear the specified register at the time of program start-up.

Action flag: Bit 0=0 of S3+1 is a positive action, and bit0=1 is a reverse action;

When heating, is reverse action.

5. Example

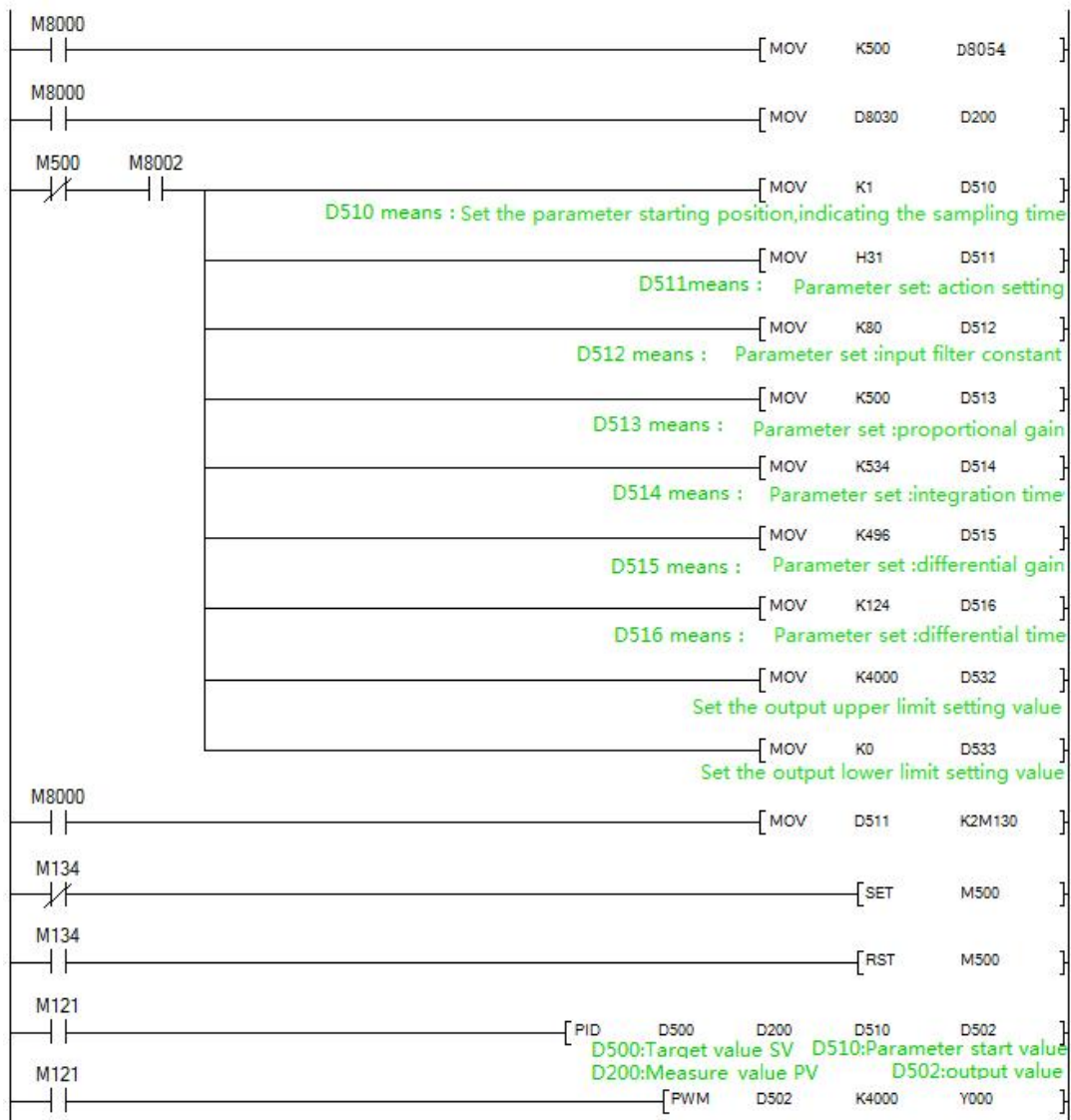

6. Application of high speed counter

6.1 Assignment table of built-in high speed counter

Counter type	Counter No.	Input assignment					
		X0 00	X0 01	X0 02	X0 03	X0 04	X0 05
Single phase single counter input	C235	U/ D					
	C236		U/ D				
	C237			U/ D			
	C238				U/ D		
	C239					U/ D	
	C240						U/ D
	C241	U/ D	R				
	C242			U/ D	R		
	C243					U/ D	R
	C244	U/ D	R				
	C245			U/ D	R		
Single phase double counter input	C246	U	D				
	C247	U	D	R			
	C248				U	D	R
	C249	U	D	R			
	C250				U	D	R
AB phase double counter input	C251	A	B				
	C252	A	B	R			
	C253				A	B	R

U: up counter

D: down counter

A: A phase input

B: B phase input

R: External reset input

Single phase: up to 6 channels, Max frequency 2 channels 60KHz+4 channels 10KHz

AB (Z) phase: 1 times frequency: 1 channel AB (Z) phase 30KHz +1 channel AB (Z) phase 5KHz;

4 times frequency: up to 2 channels, Max frequency 10KHz;

M8198 is the 4 times frequency logo of C251;

M8199 is the 4 times frequency logo of C253

6.2 Related device

1. For switching between up/down counting of single-phase single-count input counter

Type	Counter No.	Designated device	Increment count	Decrement count
Single-phase single-count input	C235	M8235	OFF	ON
	C236	M8236		
	C237	M8237		
	C238	M8238		
	C239	M8239		
	C240	M8240		
	C241	M8241		
	C242	M8242		
	C243	M8243		
	C244	M8244		
C245	M8245			

2. Single-phase dual-count and dual-phase dual-count input counters for monitoring the up/down counting direction

Type	Counter No.	Designated device	Increment count	Decrement count
Single-phase dual-count input	C246	M8246	OFF	ON
	C247	M8247		
	C248	M8248		
	C249	M8249		
	C250	M8250		
Dual-phase dual-count input	C251	M8251	OFF	ON
	C252	M8252		
	C253	M8253		

3. For high-speed counter function switching

Device	Name	Content
M8198	Function switching device	1x/4x switching device for C251 and C252
M8199		1x/4x switching device for C253

7. Application of high speed pulse output

7.1 high speed pulse output

Coolmay M3S PLC default has 4 channels high speed pulse, Y0~Y1 each 100KHZ, Y2~Y3 each 10KHZ, variable speed supported, the initial/final speed of start/stop is 0, diagram as below: (take accelerate and decelerate time D8348 as an example).

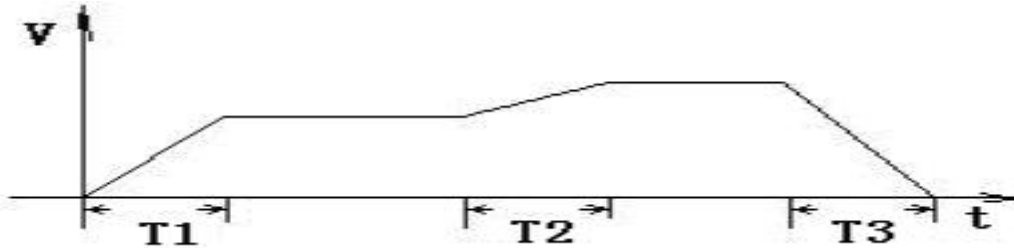

Acceleration and deceleration time T calculation = (target speed --- current speed) *
acceleration and deceleration time / maximum speed

For example: target speed = 50000, current speed = 20000, acceleration time 100 (ms),
maximum speed = 100000, T = 30 ms.

The following registers are supported when using PLSV, DRVI, DRVA, DVIT (interrupt positioning), ZRN, DSZR (origin return with DOG search) instructions:

Pulse point Function Description	Y0	Y1	Y2	Y3
Pulse operation monitoring	M8340	M8350	M8360	M8370
Position pulse (32bit)	D8340 D8341	D8350 D8351	D8360 D8361	D8370 D8371
Accelerate / Decelerate time	D8348 D8349	D8358 D8359	D8368 D8369	D8378 D8379
Pulse stop bit	M8349	M8359	M8369	M8379
Maximum speed (32bit)	D8343 D8344	D8353 D8354	D8363 D8364	D8373 D8374
basal velocity	D8342	D8352	D8362	D8372
Origin return speed	D8346 D8347	D8356 D8357	D8366 D8367	D8376 D8377
Crawl speed	D8345	D8355	D8365	D8375

The following registers are supported when using PLSR and PLSY instructions:

Pulse point Function Description	Y0	Y1	Y2	Y3
--	----	----	----	----

Pulse operation monitoring	M8340	M8350	M8360	M8370
Position pulse (32bit)	D8340	D8350	D8360	D8370
	D8341	D8351	D8361	D8371
Pulse stop bit	M8349	M8359	M8369	M8379
Maximum speed (32bit)	D8343	D8353	D8363	D8373
	D8344	D8354	D8364	D8374

7.2 Pulse width modulation (PWM)

1. Outline

This instruction is used to specify the pulse period and pulse output of the ON time.

2. PWM instruction format and parameter description.

Instruction format:

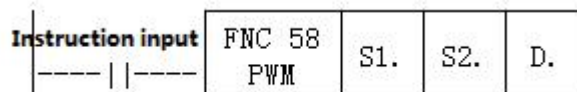

Parameter description:

Operand type	Content	Data type	Word software component	Range
S1.	Word soft component numbers of Pulse width (ms) data or saving data	BIN 16 bit	KnX, KnY, KnM, KnS, T, C, D, R, V, Z, K, H	0~32767ms
S2.	Word soft component numbers of Period (ms) data or saving data	BIN 16 bit	KnX, KnY, KnM, KnS, T, C, D, R, V, Z, K, H	1~32767ms
D.	Soft component (Y) numbers of Output pulse	BIN 16 bit	Y0-Y3	Y0-Y3

3. Function and action description

16-bit operation (PWM):Pulse output in units of period [S2.ms],Its ON pulse width is [S1.ms].

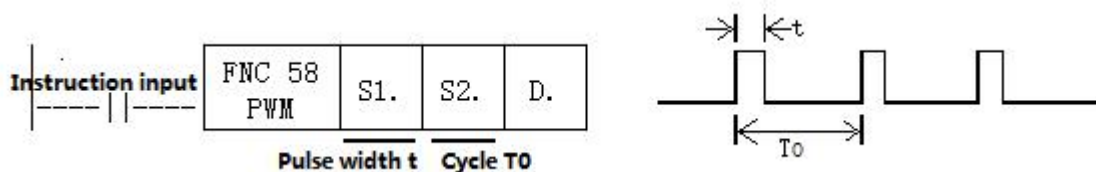

Notes:

Value of the pulse width S1. and the period S2. should be set: $S1. \leq S2.$

When instruction input is OFF, Output from D. is also OFF.

Do not operate the setting switch of the pulse output mode during pulse emission.

4. Program Example

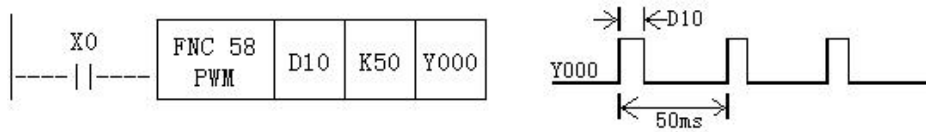

In this example, the data range of D10 is changed from 0 to 50, and the average output of Y0 is 0 to 100%. If D10 data >50, it will be wrong.

Example for smooth loop

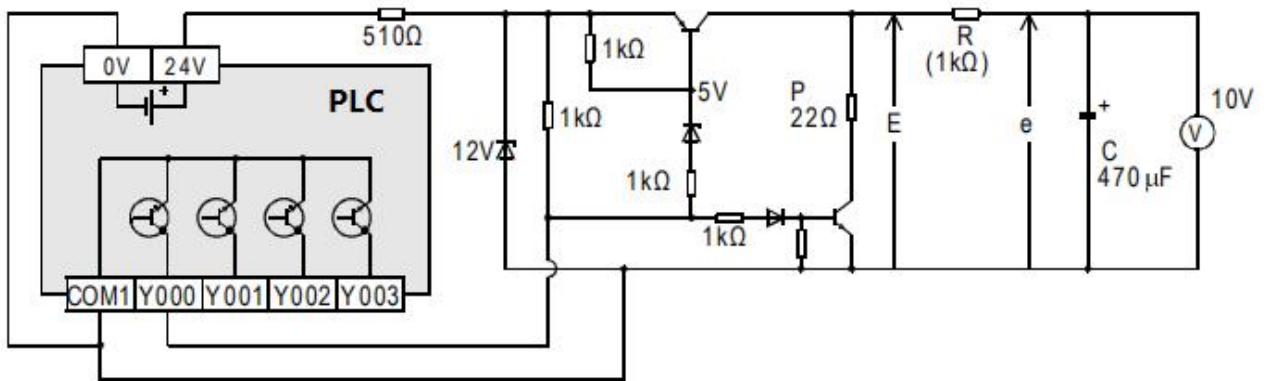

$$R \gg P$$

$$t = R(K\Omega) * C(\mu F) = 470ms \gg T0$$

Compared to the pulse period $T0$, the time constant τ of the filter is a very large value.

The fluctuation value Δe of average output current e is approximately $\frac{\Delta e}{e} \approx \frac{T0}{\tau}$

5. Special Note

Conventional PWM

- 1) Support a total of 4 channels Y0-Y3 (please select transistor MT output);
- 2) There is no limit to the pulse width and pulse period, both in milliseconds (ms).

8. Coolmay M3S PLC Communication Instructions

M3S PLC has default RS232 programming port, and two communication ports (Rs232 or Rs485) can be added. Meanwhile, CANbus is also optional.

8.1 MODBUS instruction interpretation and communication address

PLC, when as master, support ADPRW command, RD3A command, WR3A command, this section will give you detailed description about these commands.

8.1.1 RD3A/WR3A command function and action description:

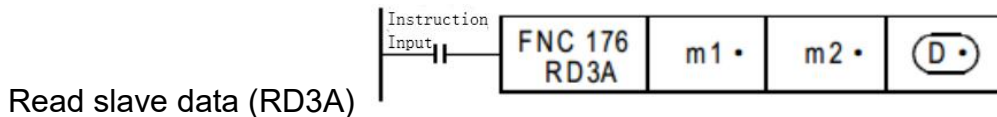

For CoolMay PLC, the RD3A instruction corresponds to Modbus's No. 03 function.

In the instruction,

m1 represents the station number of the read slave device, range: 1-247;

m2 represents the first address number of the read data in the slave device;

D represents the number of registers read, range: 1-125 (When Modbus ASCII, range is 1-45; When CAN communication, range is 1-90), and the read data is sequentially stored in the host D.+1, D.+2.

D-1 address value must be set to (=0: serial port 2; =1: serial port 3)

Write data to the slave (WR3A):

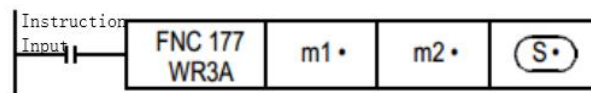

For CoolMay PLC, the WR3A instruction corresponds to Modbus's 06 and 10 functions.

In the instruction,

m1 represents the station number of the slave device to be written, range :1-247.

m2 represents the first address number of the write register in the slave

device;

S represents the numbers of registers to be written, ranging:1-123(When Modbus ASCII,range is1-45; When CAN communication,range is 1-90). The data to be written is sequentially stored in the host S.+1, S.+2.

S=1, the WR3A instruction corresponds to the Modbus 06 function.

S=2-123, the WR3A instruction corresponds to the Modbus 10 function.

S.-1 address value must be set to (=0: serial port 2; =1: serial port 3)

RD3A and WR3A only support the below MODBUS functions:

Function No. 03: Read holding register and takes the current binary value range of 1-125 in one or more holding registers.

Function No. 06: Load the specific binary value into a holding register (write register) ,range:1.

Function No. 16: Preset multiple registers, load specific binary values into a series of consecutive holding registers (write multiple registers),range:1-123.

8.1.2 ADPRW command function and action description

ADPRW instruction supports all functions of the MODBUS RTU.

No. 01: Read coil status and get the current status (ON/OFF) of a group of logic coils, range 1-512

No. 02: Read the input status and get the current status (ON/OFF) of a group of switch inputs, range 1-512

No. 03: Read the retentive register and get the current binary value in one or more retentive registers, ranging from 1-125

No. 04: Get the current binary value in one or more input registers, range 1-125

No. 05: Force a single coil to force the on/off state (write bit) of a logic coil, range 1

No. 06: Load specific binary values into a retentive register (write register), range 1

No. 0F: Force multiple coils, forcibly open and close a series of continuous logic coils (write multiple bits), range 1-1968

No. 10: Preset multiple registers, load specific binary values into a series of consecutive holding registers (write multiple registers). Range 1-125

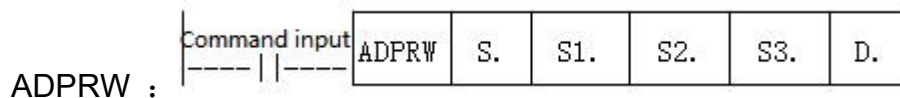

S. indicates the station number of the slave device to be read and written, the range is 0-247;

S1. indicates the function code (that is, the functions NO 01-06, 15, and 16);

S2. The function parameter corresponding to each function code (the operand indicates the MODBUS start address when the function is 01);

S3. The function parameters corresponding to each function code (the operand indicates the number of access points when the function is 01, and the parameter is fixed to 0 when the 05 function is used);

D. indicates the starting position of the data storage device.

8.1.3 Word device Communication address number

MODBUS device		M3S device
Input register (readout dedicated)	Holding register (read/write)	
-	0x0000~0x1F3F	D0~D7999
-	0x1F40~0x213F	D8000~D8511
-	0x2140~0x7EFF	R0~R23999
-	0x7F00~0xA13F	Unused address
-	0xA140~0xA27F	TN0~TN319
-	0xA280~0xA33F	Unused address
-	0xA340~0xA407	CN0~CN199
-	0xA408~0xA477	CN200~CN255
-	0xA478~0xA657	M0~M7679
-	0xA658~0xA677	M8000~M8511
-	0xA678~0xA777	S0~S4095
-	0xA778~0xA78B	TS0~TS319
-	0xA78C~0xA797	Unused address
-	0xA798~0xA7A7	CS0~CS255
-	0xA7A8~0xA7AF	Y0~Y177
0xA7B0~0xA7B7	-	Unused address
0xA7B8~0xA7BF	-	X0~X177
An error occurs when accessing an unused address		
CN200~255 is a 32-bit counter		

8.1.4 Bit device Communication address number

MODBUS device		M3S device
Input (readout dedicated)	Coil (read/write)	
-	0x0000~0x1DFF	M0~M7679
-	0x1E00~0x1FFF	M8000~M8511
-	0x2000~0x2FFF	S0~S4095
-	0x3000~0x313F	TS0~TS319
-	0x3140~0x31FF	Unused address
-	0x3200~0x32FF	CS0~CS255
-	0x3300~0x337F	Y0~Y177
0x3380~0x33FF	-	Unused address
0x3400~0x347F	-	X0~X177
An error occurs when accessing an unused address CN200~255 is a 32-bit counter		

8.1.5 ADPRW Command function parameter

Operand function	S1. Function code	S2. MODBUS address/subfunction code	S3. Access points/subfunction data	D. Data storage device start
Coil readout	1H	MODBUS Address: 0000H~FFFFH	Access points: 1~2000	Read object device D.R.M.Y.S
Input readout	2H	MODBUS Address: 0000H~FFFFH	Access points: 1~2000	Read object device D.R.M.Y.S
Holding register readout	3H	MODBUS Address: 0000H~FFFFH	Access points: 1~125	Read object device D.R
Input register readout	4H	MODBUS Address: 0000H~FFFFH	Access points: 1~125	Read object device D.R
Single coil write	5H	MODBUS Address: 0000H~FFFFH	0(Fix)	Write object device D.R.X.Y.M.S 0=OFF 1=ON
Single register write	6H	MODBUS Address: 0000H~FFFFH	0(Fix)	Write object device D.R

Bulk coil writing	FH	MODBUS Address: 0000H~FFFFH	Access points: 1~1968	Write object device D.R.X.Y.M.S
Bulk register write	10H	MODBUS Address: 0000H~FFFFH	Access points: 1~123	Write object device D.R

8.2 Serial port 1: RS232(PLC programming port)

Support Mitsubishi programming port protocol; Can be used to download PLC program or communicate with devices which support MITSUBISHI programming port protocol.

8.3 Serial port2:RS485(A B)/RS232

Support Mitsubishi programming port protocol, RS protocol and MODBUS RTU protocol;

The special relays and registers related to this serial port are as below

Functions	Serial port 2(A/B)	Serial port 3(A1/B1)	Remark
Mitsubishi programming port protocol	M8196=0	M8192=0	Power lost can not be retentive
Freeport protocol function	M8196=1 M8125=0	M8192=1	
RS/RS2 sending mark	M8122=1	M8402=1	
RS/RS2 sending completion mark	-	-	Need to reset manually
RS/RS2 receiving completion mark	M8123	M8403	Need to reset manually
RS/RS2 receiving process mark	M8124	M8404	Data is receiving
RS/RS2 command 8/16 bits differentiation mark	M8161	M8161	
RS2 command end operation settings	-	1	
MODBUS function	M8196=1 M8125=1	M8192=1	
RD3A\WR3A Receive correct mark	M8128	M8408	Automatic reset
RD3A\WR3A communication over-time mark	M8129	M8409	Automatic reset
ADPRW command completion	M8029	M8029	Command execution end

mark			mark
Communication parameters	D8120	D8400	
Communication mode	-	D8401	
Master-slave station number	D8121	D8414	
RD3A/WR3A overtime	D8129	D8409	Unit: ms (detailed setting, refer to explanation)
RD3A/WR3A interval period	D8126	D8406	
RD3A\WR3A end operation -1	0	1	
ADPRW command settings	D8397=0	D8397=1	

M8196: the activation flag of using programming port protocol and other protocol .

M8125: the activation flag of using MODBUS and the original Mitsubishi function.

M8122: RS sending flag (this bit needs to be set 1 when using the RS instruction, and it will automatically reset after sending).

M8123: RS receiving completion flag (need to reset manually).

M8124: RS command data is being received.

M8161: 8-bit/16-bit mode flag of RS instruction .

M8128: RD3A / WR3A receive the correct flag.

M8129:RD3A/WR3A communication over-time flag. (when communication is over-time, flag is ON)

M8029: Communication completion flag (communication completion flag when using ADPRW instruction, needs to be reset by hand).

D8120: The detailed communication parameter settings of saving Modbus RTU protocol are seen as below.

D8121: Save the host or slave station number. (It must be set as max. K255 as master)

D8129: RD3A and WR3A timeout period. **(The unit is milliseconds, it is recommended to set: when the communication rate setting is greater than or equal to 9600, D8129 is set to 10~20; when the communication rate setting is less than 9600, D8129 is set to 20~50;)**

D8126: The number of interval cycles. Default=10 (times).

D8397: When using the serial port 2 for ADPRW instruction, D8397 needs to be set to 0.

Support RS, WR3A, RD3A, ADPRW instructions. Can be set in the parameter zone, corresponding to serial port 2. The parameter zone settings are only valid for this channel. It is invalid for serial port 3.

8.3.1 Mitsubishi programming port

When used as Mitsubishi programming port protocol: set M8196=0.

8.3.2 Mitsubishi BD Agreement

When used as the Mitsubishi BD protocol function: set M8196=1, M8125=0; D8120 is set as the communication parameter, and D8121 is set as the slave station number. For example, set D8120=H6086, D8121=H1 (communication parameter is 9600/7/E/1, slave station number is 1).

D8120 parameter setting:

b15	b14	b13	b12	b11	b10	b9	b8	b7	b6	b5	b4	b3	b2	b1	b0
-----	-----	-----	-----	-----	-----	----	----	----	----	----	----	----	----	----	----

b0	Data length 0:7 位 1:8 位
b1	Parity(b2, b1)
b2	00:None; 01:Odd; 11:Even
b3	Stop bit 0:1bit 1:2bit
b4	Baud rate (b7, b6, b5, b4)
b5	(0100):600bps (0101):1200bps (0110):2400bps
b6	(0111):4800bps (1000):9600bps (1001):19200bps
b7	(1010):38400bps (1011):57600bps (1101):115200bps
b8	Set0
b9	
b10	
b11	

b12	Set 0
b13	Set 1
b14	Set 1
b15	Set 0

Example of PLC as slave program:



8.3.3 Freeprot protocol function and example

When used as a Mitsubishi Freeprot protocol function: set M8196=1, M8125=0. The difference between Mitsubishi protocol 1 and protocol 4 is that there are terminator 0A 0D (stored in D8124 and D8125 respectively).

For Mitsubishi Freeprot protocol, RS instruction is supported, D8120 only needs to set the value of the lower 8 bits.

b7	b6	b5	b4	b3	b2	b1	b0
----	----	----	----	----	----	----	----

b0	Data length 0:7 bits 1:8bits		
b1	Odd and Even (b2,b1)		
b2	00: None 01: Odd 02: Even		
b3	Stop bit 0: 1 bit 1: 2 bits		
b4	BPS rate (b7,b6,b5,b4)		
b5	(0100):600bps	(0101):1200bps	(0110):2400bps
b6	(0111):4800bps	(1000):9600bps	(1001):19200bps
b7	(1010):38400bps	(1011):57600bps	(1101):115200bps

Program example:

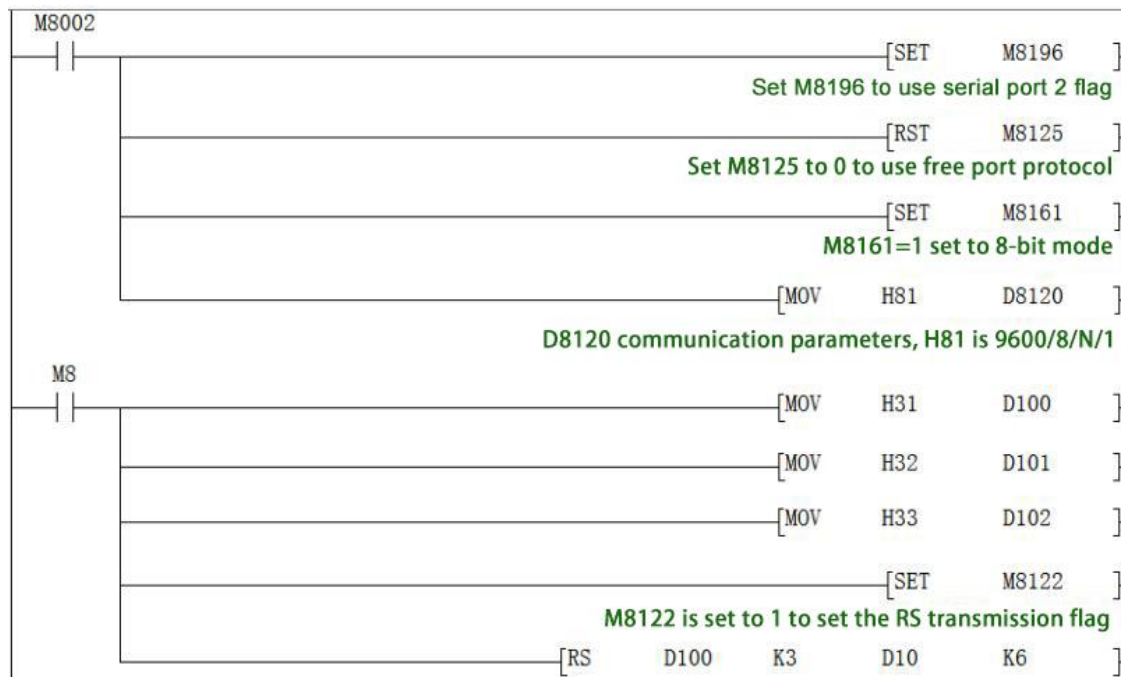

Use the serial port tool by serial port 2 to monitor the data obtained is

[2017:11:01:10:49:16][receive]31 32 33

8.3.4 Modbus RTU Protocol

When used as Modbus RTU: set M8196=1,M8125=1; set D8120 as communication parameters, D8121 set as slave station. For example: D8120=HE081,D8121=H1(communications parameter as 9600/8/n/1,station number is 1).

D8120 Parameter set

b15	b14	b13	b12	b11	b10	b9	b8	b7	b6	b5	b4	b3	b2	b1	b0
-----	-----	-----	-----	-----	-----	----	----	----	----	----	----	----	----	----	----

Bit number	Content
b0	Data length 0:7 bit 1:8 bit
b1 b2	Parity (b2,b1) 00:None 01:Odd 11:Even
b3	Stop bit 0:1 bit 1:2 bit

	Baud rate (b7 b6 b5 b4)
	0100:600bps
	0101:1200bps
b4	0110:2400bps
b5	0111:4800bps
b6	1000:9600bps
b7	1001:19200bps
	1010:38400bps
	1011:57600bps
	1100:115200bps
b8	Set 0
b9	
b10	
b11	
b12	RTU/ASCII Mode Selection 0:RTU 1:ASCII
b13	Set 1
b14	Set 1
b15	Set 1

RD3A Program example (refer to [8.1.1](#)):

Slave program:

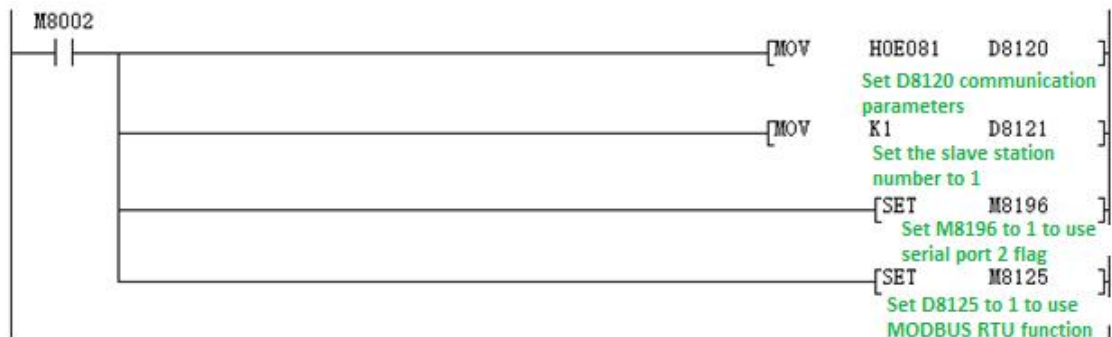

Master program:

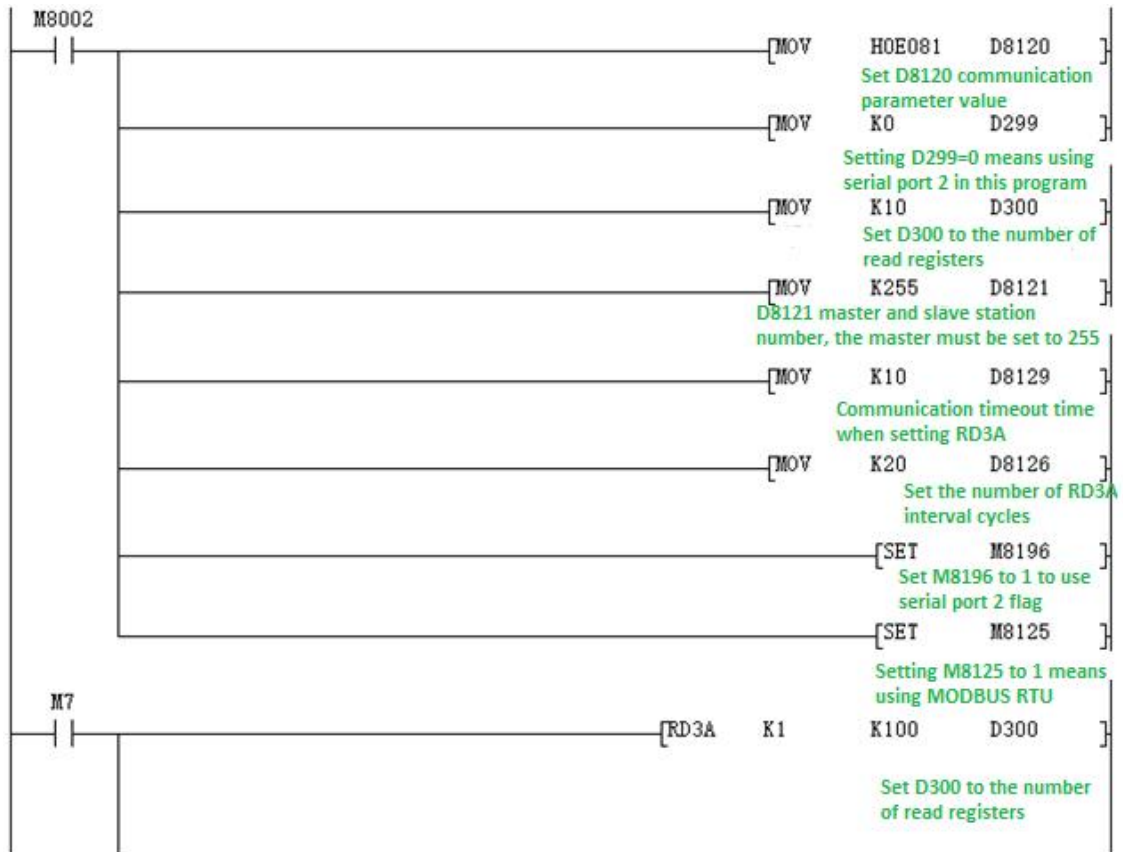

Program explanation:

D300 saves the number of registers read, here it means reading 10 data.

When using serial port 2, D299 at D.-1 must be set to 0.

This program represents that 10 data of the registers D100-D109 in the PLC with the slave station 1 are read and stored in the registers D301-D310 of the master station PLC.

WR3A Program example (refer to [8.1.1](#)):

Master program:

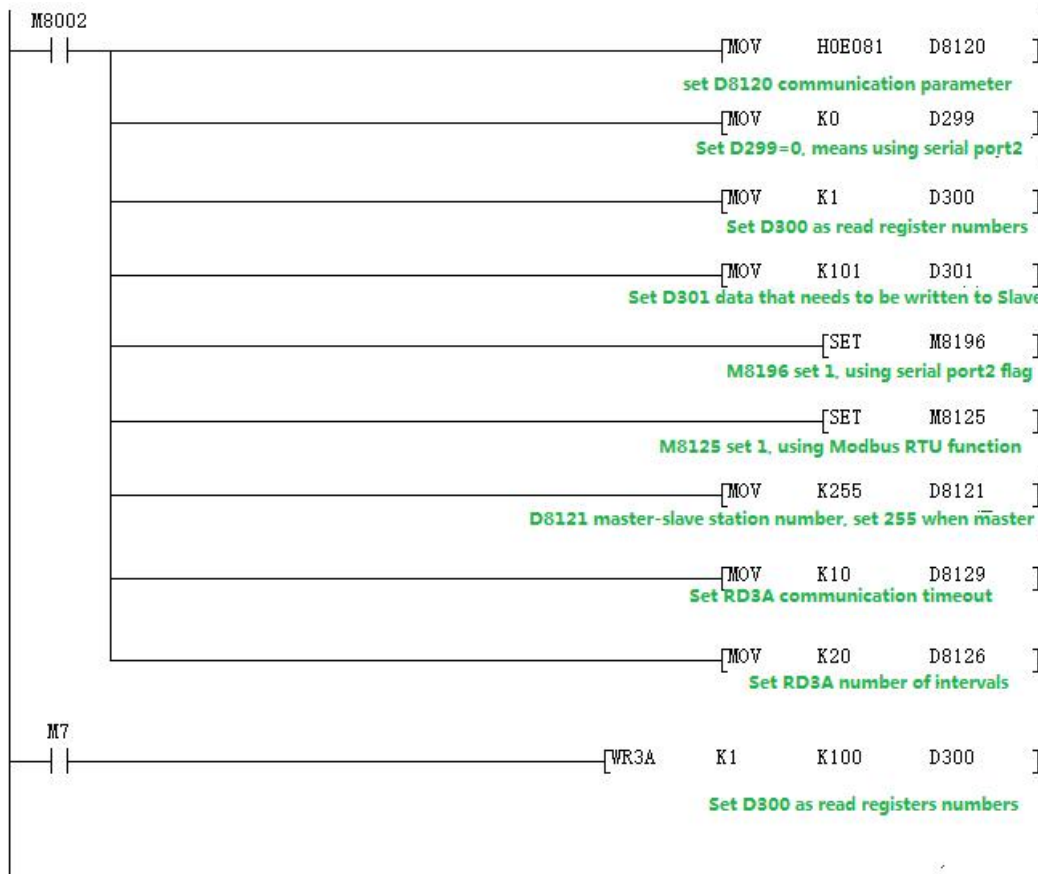

Slave program:



Program explanation:

This program represents that 1 data of the register D301 in the master PLC is written to the PLC in Slave 1, and is stored in the register D100 of the slave PLC.

8.3.5 MODBUS RTU ADPRW command

03 function code hold register output. (refer to [8.1.2](#)):

Master program:

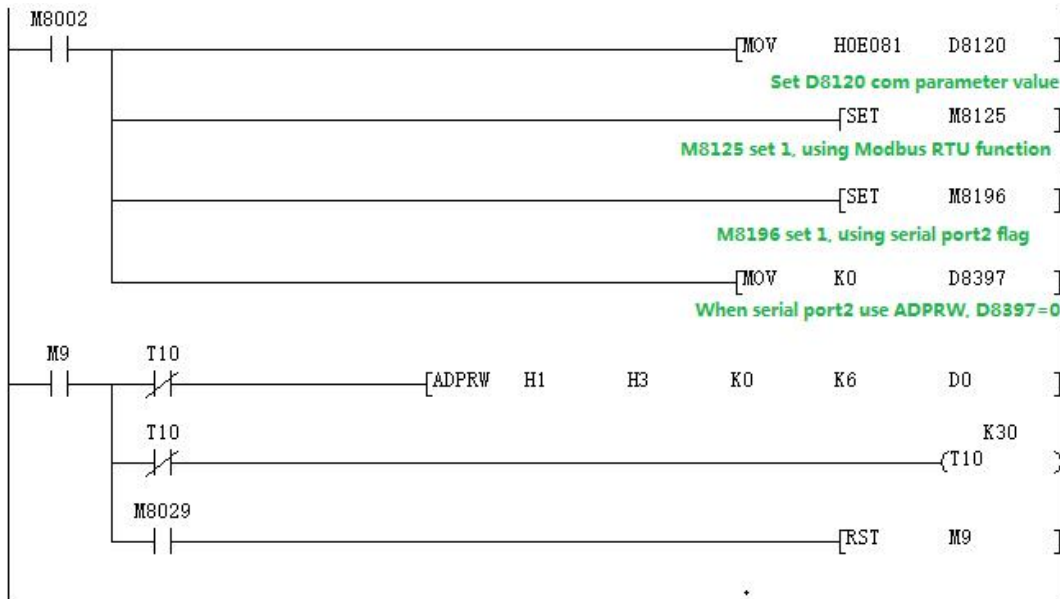

Slave program:

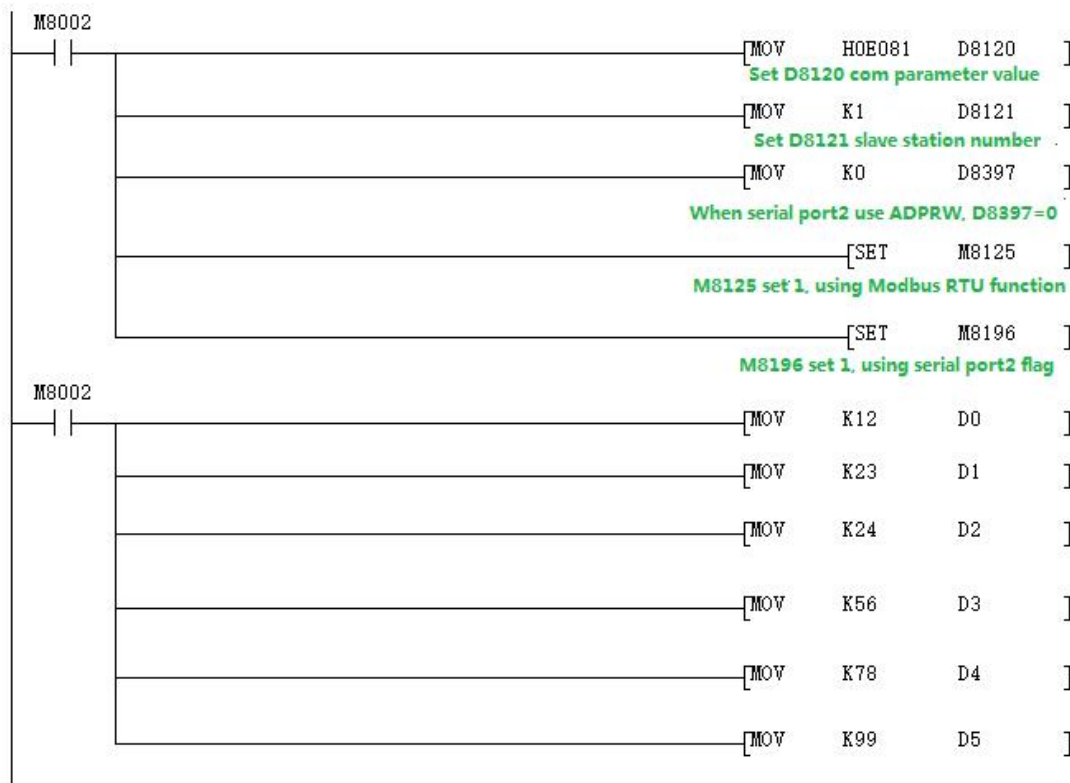

Use the serial port tool to monitor serial port 2 for below data:

[2017:11:01:17:48:54][receive]01 03 00 00 00 06 C5 C8

[2017:11:01:17:48:54][receive]01 03 0C 00 0C 00 17 00 22 00 38 00 4E 00

63 C4 29

8.3.6 Modbus ASCII Protocol

When used as **Modbus ASCII** protocol, specific parameter setting pls refer to [8.3.3](#), Only the 12th bit of D8120 is set differently, checking D8120 parameter setting in section 8.3.3.

Note: In **modbus ASCII** protocol, **ADPRW command** is not supported.

Program example:

Master program:

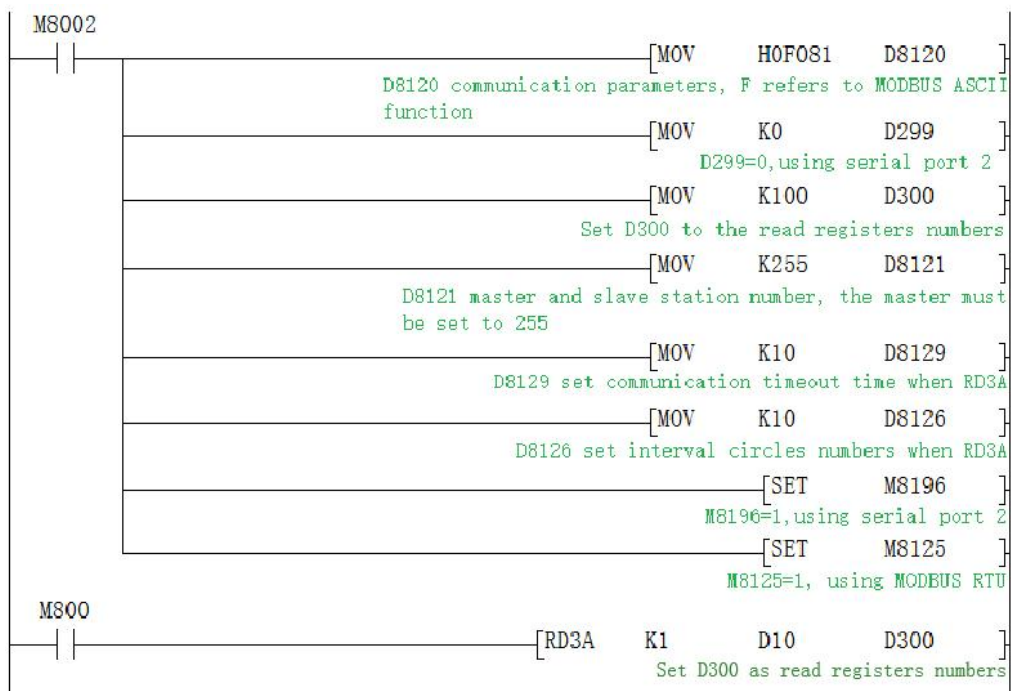

Slave program:

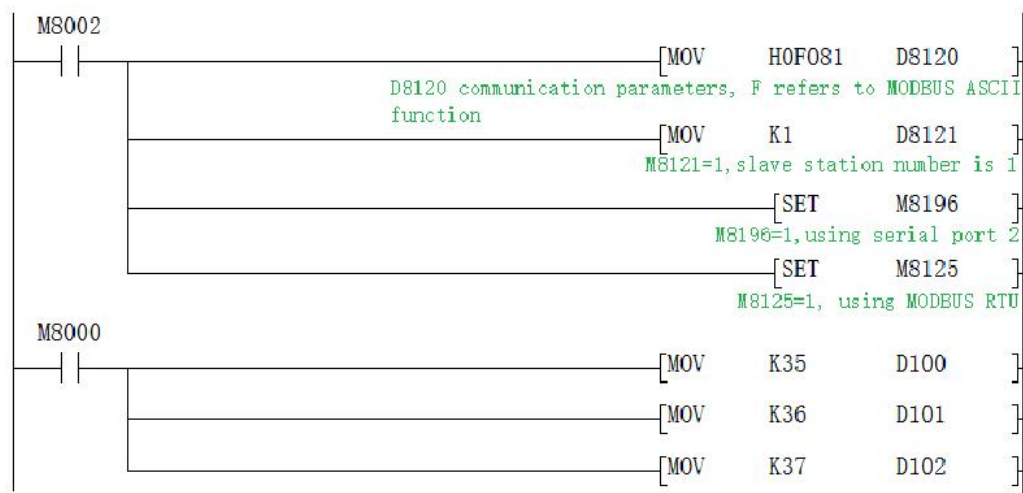

Data of the Master D300~D303 before and after the program execution is showed as below.

Soft components	+F E D C	+B A 9 8	+7 6 5 4	+3 2 1 0	
D300	0 0 0 0	0 0 0 0	0 0 0 0	0 0 1 1	3
D301	0 0 0 0	0 0 0 0	0 0 0 0	0 0 0 0	0
D302	0 0 0 0	0 0 0 0	0 0 0 0	0 0 0 0	0
D303	0 0 0 0	0 0 0 0	0 0 0 0	0 0 0 0	0

Monitor D300-D301 data before the master M7 turns on.

Soft components	+F E D C	+B A 9 8	+7 6 5 4	+3 2 1 0	
D300	0 0 0 0	0 0 0 0	0 0 0 0	0 0 1 1	3
D301	0 0 0 0	0 0 0 0	0 0 1 0	0 0 1 1	35
D302	0 0 0 0	0 0 0 0	0 0 1 0	0 1 0 0	36
D303	0 0 0 0	0 0 0 0	0 0 1 0	0 1 0 1	37
D304	0 0 0 0	0 0 0 0	0 0 0 0	0 0 0 0	0

Monitor D300-D301 data after the master M7 turns on.

8.4 Serial port 3:RS485(A1 B1)

Support Mitsubishi programming port protocol,RS2 protocol and MODBUS RTU protocol.

The special relays and registers related to this serial port are as below.

Functions	Serial port 2(A/B)	Serial port 3(A1/B1)	Remark
Mitsubishi programming port	M8196=0	M8192=0	Power lost can not be retentive
Freeport protocol function	M8196=1 M8125=0	M8192=1	
RS/RS2 sending mark	M8122=1	M8402=1	
RS/RS2 sending completion mark	-	-	Need to reset manually
RS/RS2 receiving completion mark	M8123	M8403	Need to reset manually
RS/RS2 receiving process mark	M8124	M8404	Data is receiving
RS/RS2 command 8/16 bits differentiation mark	M8161	M8161	
RS2 command end operation settings	-	1	
MODBUS function	M8196=1 M8125=1	M8192=1	
RD3A/WR3A Receive correct mark	M8128	M8408	Automatic reset
RD3A\WR3A communication over-time mark	M8129	M8409	Automatic reset
ADPRW command completion mark	M8029	M8029	Command execution end mark
Communication parameters	D8120	D8400	
Communication mode	-	D8401	

Master-slave station number	D8121	D8414	
RD3A/WR3A overtime	D8129	D8409	Unit: ms (detailed setting, refer to explanation)
RD3A/WR3A interval period	D8126	D8406	
RD3A/WR3A end operation -1	0	1	
ADPRW command settings	D8397=0	D8397=1	

M8192: the activation mark of using programming port protocol and other protocol. (power lost not retentive).

M8402: Send mark (use when RS2 command).

M8403: Communication completion mark (communication completion flag when using RS command, needs manual reset).

M8404: Data is receiving.

M8408: Communication completion mark (Valid while using ADPRW command).

M8409: Communication time out.

M8029: Communication completion mark (communication completion mark while using ADPRW instruction and needs manual reset).

M8161: 8-bit/16-bit mode distinguishing mark for RS/RS2 command.

D8400: Save the communication parameters of the Modbus RTU protocol.

D8401: Save the communication mode of serial port 3.

D8401=H0 represents the RS free communication mode.

When Modbus RTU: D8401=H11 represents PLC as Slave. D8401=H1 represents PLC as Master.

When Modbus ASCII: D8401=H111 represents PLC as Slave; D8401=H101 represents PLC as Master.

D8406: Interval period. Default as 12 times.

D8409: overtime time. (The unit is milliseconds, it is recommended to set: when the communication rate is greater than or equal to 9600, D8409 is set to 10~20; when the communication rate is set to less than 9600, D8409 is set to 20~50;)

D8414: Save the master or slave station number (The value must be set as max K255 as master).

D8397: When using the ADPRW instruction, use serial port 3, and D8397 must be set to 1.

Support RS2,WR3A,RD3A,ADPRW commands. Can be set in parameter zone, correspond to serial port 3. Parameter zone settings are valid only for this channel. Invalid for serial port 2.

D8400 Parameter set

Bit number	Content
b0	Data length 0:7 bit 1:8 bit
b1 b2	Parity (b2,b1) 00:None 01:Odd 11:Even
b3	Stop bit 0:1 bit 1:2 bit
b4 b5 b6 b7	Baud rate (b7 b6 b5 b4) 0100:600bps 0101:1200bps 0110:2400bps 0111:4800bps 1000:9600bps 1001:19200bps 1010:38400bps 1011:57600bps 1100: Not use 1101:115200bps
b8-b15	Unavailable, Set 0

D8401 Parameter set

b0	Select protocol 0: Other communication protocol 1: MODBUS protocol
b1~b3	Unavailable, Set 0
b4	Master/Slave setting 0: MODBUS Master 1: MODBUS Slave

b5~b7	Unavailable, Set 0
b8	RTU/ASCII Mode selection 0:RTU 1:ASCII
b9~b15	Unavailable, Set 0

8.4.1 Mitsubishi programming protocol

When using as mitsubishi programming port protocol: set M8192=0.

8.4.2 Free port protocol function

When using as mitsubishi free port protocol: set M8192=1, M8402=1;

Program example:

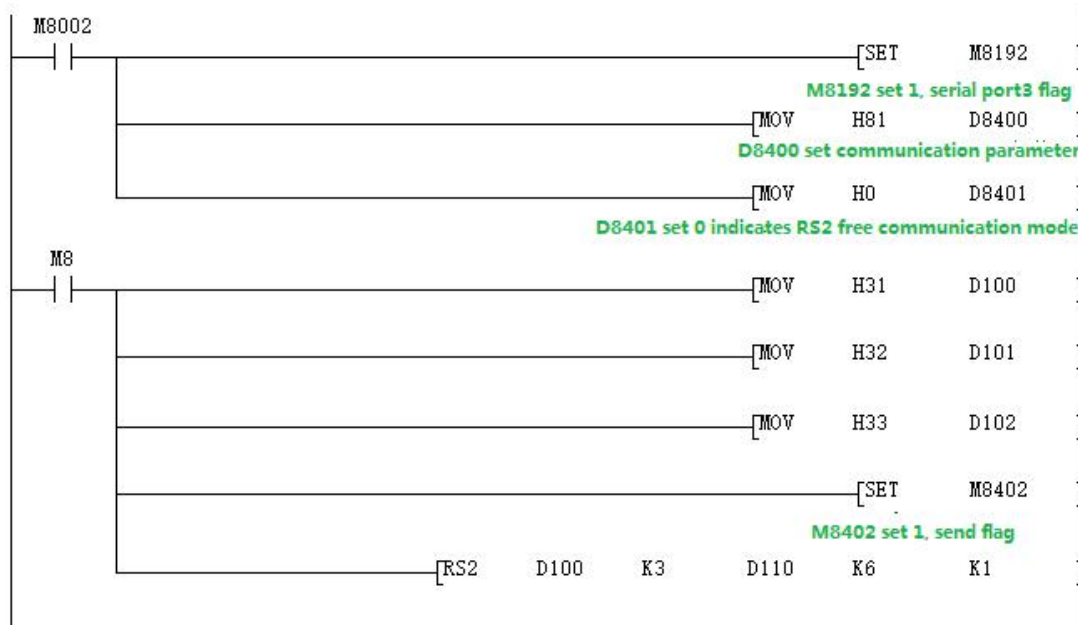

Use the serial port tool to monitor serial port 3 for data:

[2017:11:01:11:49:16][receive]31 32 33

Last parameter of RS2 instruction =1: Serial port 3

8.4.3 Modbus RTU protocol RD3A/WR3A command

Used as MObus RTU: set M8192=1; set D8400 as communication parameters, set D8414 s as master slave station no. For example: D8400=H81, D414=K1 (communications parameter as 9600/8/n/1,slave station number is 1)

RD3A Program Example (Refer to [8.1.1](#)):

Slave program:



Master program:



Use the serial port tool to monitor serial port 3 for below data:

[2017:11:01:09:00:11][receive]01 03 00 64 00 0A 84 12

[2017:11:01:09:00:11][receive]01 03 14 00 42 00 4D 00 58 00 58 00 63 00

37 00 2C 00 21 00 16 00 0B 9F C7

WR3A Program Example (Refer to [8.1.1](#)):

Slave program:



Master program:

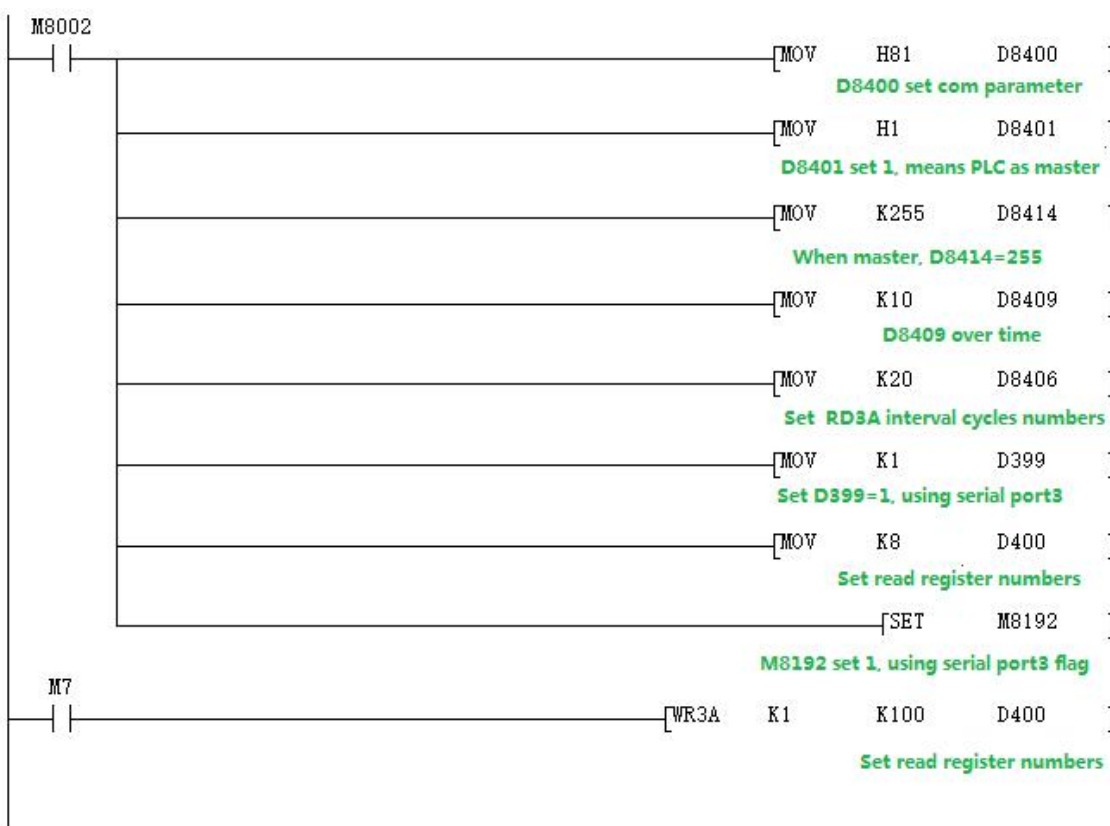

Use the serial port tool to monitor serial port 3 for below data:

[2017:11:01:09:25:20][receive]01 10 00 64 00 08 10 00 0B 00 16 00 21 00
2C 00 37 00 42 00 4D 00 58 D1 6C

[2017:11:01:09:25:20][receive]01 10 00 64 00 08 10 00 0B 00 16 00 21 00
2C 00 37 00 42 00 4D 00 58 D1 6C

8.4.4 MODBUS RTU ADPRW Command

04 register input readout. Program Example (Refer to 8.1.2):

Master program

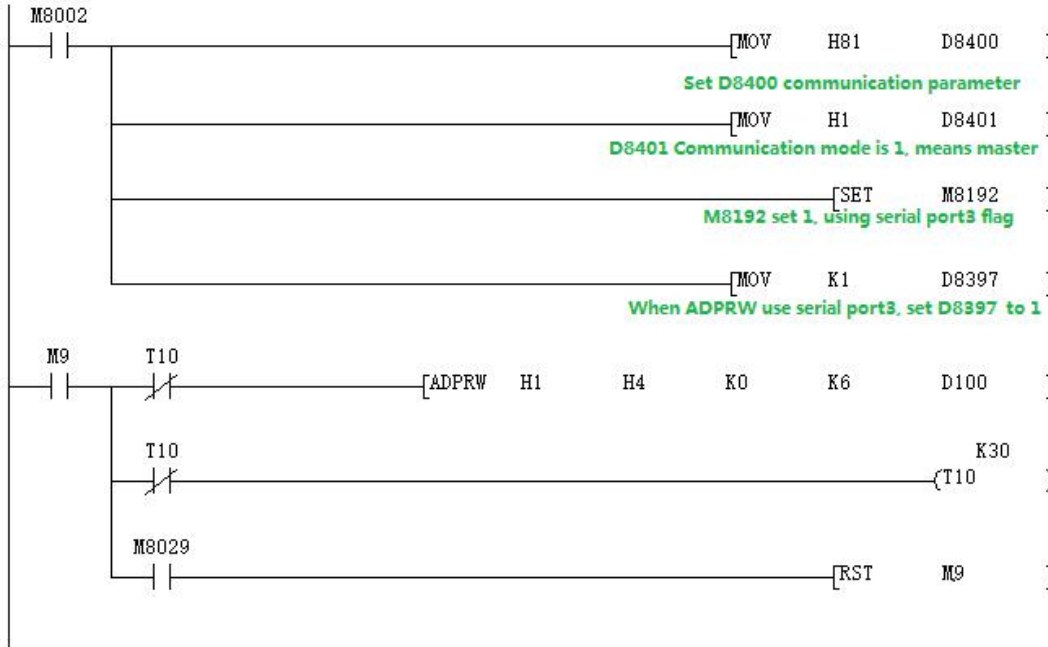

Slave program

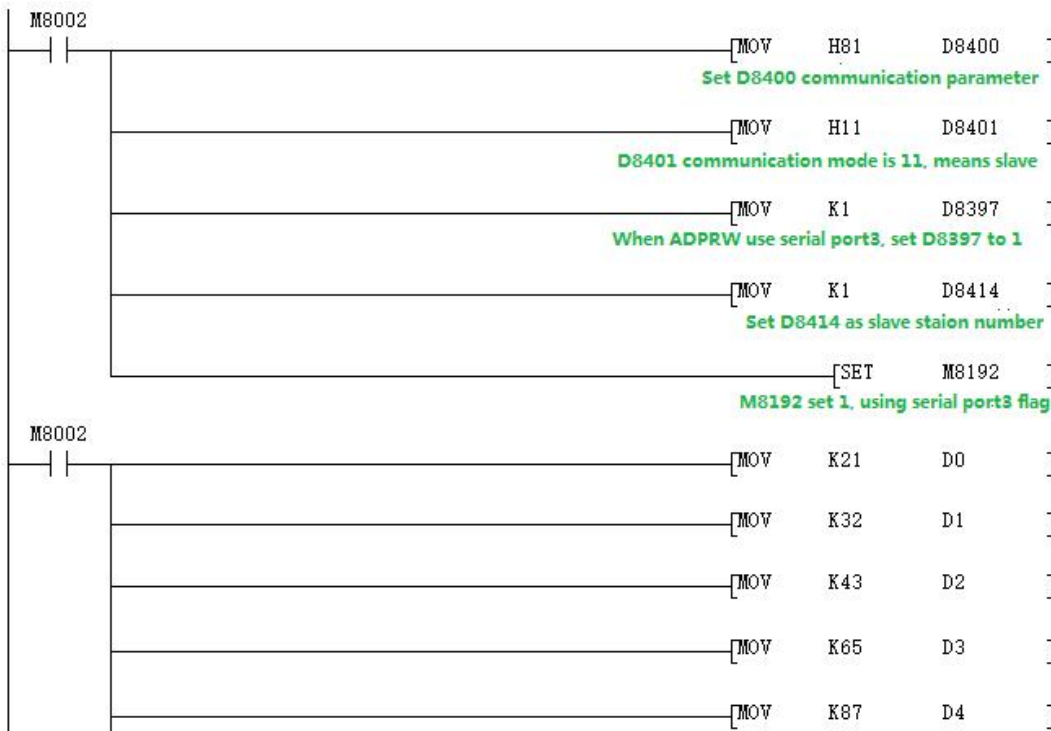

Use the serial port tool to monitor serial port 3 for below data:

[2017:11:01:17:38:34][receive]01 04 00 00 00 06 70 08

[2017:11:01:17:38:34][receive]01 04 0C 00 15 00 20 00 2B 00 41 00 57 00 00
5F A7

8.4.5 Modbus ASCII Function

When used as Modbus ASCII protocol, specific parameter setting pls refer to [8.4.3](#), Only the 8th bit of D8401 is set differently, checking D8120 parameter setting in section [8.4.3](#).

Note: In modbus ASCII protocol, ADPRW command is not supported.

Master program:

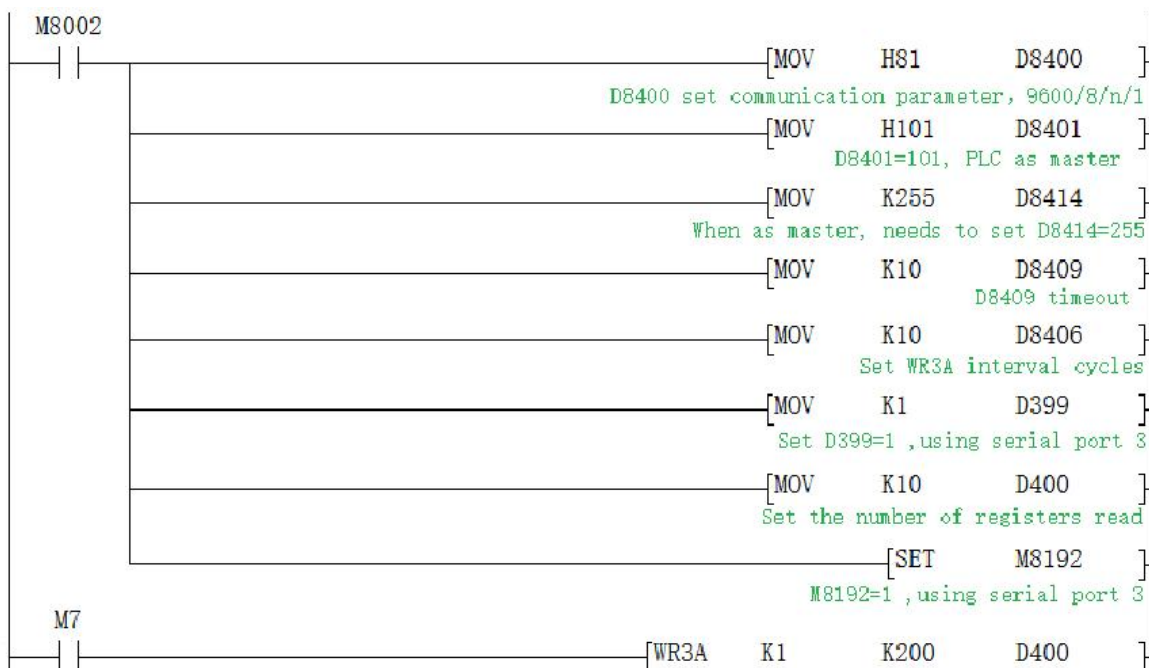

Slave program:

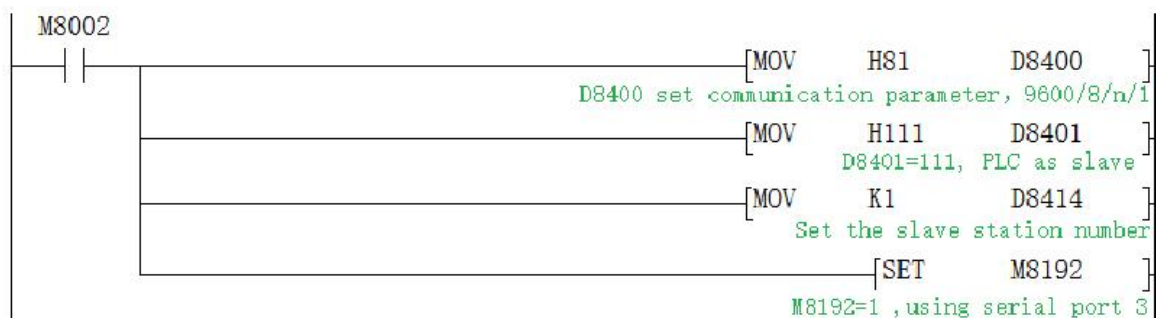

Data of the Slave D100~D109 before and after the program execution is
showed as
below

Soft components	+F E D C	+B A 9 8	+7 6 5 4	+3 2 1 0	
D100	0 0 0 0	0 0 0 0	0 0 0 0	0 0 0 0	0
D101	0 0 0 0	0 0 0 0	0 0 0 0	0 0 0 0	0
D102	0 0 0 0	0 0 0 0	0 0 0 0	0 0 0 0	0
D103	0 0 0 0	0 0 0 0	0 0 0 0	0 0 0 0	0
D104	0 0 0 0	0 0 0 0	0 0 0 0	0 0 0 0	0
D105	0 0 0 0	0 0 0 0	0 0 0 0	0 0 0 0	0
D106	0 0 0 0	0 0 0 0	0 0 0 0	0 0 0 0	0
D107	0 0 0 0	0 0 0 0	0 0 0 0	0 0 0 0	0
D108	0 0 0 0	0 0 0 0	0 0 0 0	0 0 0 0	0
D109	0 0 0 0	0 0 0 0	0 0 0 0	0 0 0 0	0
D110	0 0 0 0	0 0 0 0	0 0 0 0	0 0 0 0	0
Monitor D100-D109 data before the master M7 turns on.					
Soft components	+F E D C	+B A 9 8	+7 6 5 4	+3 2 1 0	
D100	0 0 0 0	0 0 0 0	0 0 0 0	1 0 1 1	11
D101	0 0 0 0	0 0 0 0	0 0 0 0	1 0 1 1	11
D102	0 0 0 0	0 0 0 0	0 0 0 0	1 0 1 1	11
D103	0 0 0 0	0 0 0 0	0 0 0 0	1 0 1 1	11
D104	0 0 0 0	0 0 0 0	0 0 0 0	1 0 1 1	11
D105	0 0 0 0	0 0 0 0	0 0 0 0	1 0 1 1	11
D106	0 0 0 0	0 0 0 0	0 0 0 0	1 0 1 1	11
D107	0 0 0 0	0 0 0 0	0 0 0 0	1 0 1 1	11
D108	0 0 0 0	0 0 0 0	0 0 0 0	1 0 1 1	11
D109	0 0 0 0	0 0 0 0	0 0 0 0	1 0 1 1	11
D110	0 0 0 0	0 0 0 0	0 0 0 0	0 0 0 0	0
Monitor D100-D109 data after the master M7 turns on.					

8.5 Network N:N communication

8.5.1 Related device content

1. N:N network setting device

Soft element	name	content	Set value
M8038	Parameter setting	Set the flag for communication parameters. It can also be used as a flag to confirm the presence of N:N network programs. Do not turn ON in the sequence program.	
D8176	Corresponding station number setting	N:N network setting station number when using. The master station is set to 0, and the slave station is set to 1 to 15. [Initial value: 0]	0~15
D8177	Slave total number setting	Set the total number of slave stations. No setting is required in the PLC of the slave station. [Initial value: 7]	1~15
D8178	Refresh Range setting	Select the mode of the number of device points to communicate with each other. No setting is required in the PLC of the slave station. [Initial value: 0]	0~2

D8394	Serial channel selection	=2: Serial port 2 =3: Serial port 3	2~4
-------	--------------------------	--	-----

2. Components for judging N:N network errors

M8184~M8190, M8496~M8503: The data transmission sequence error flag of the slave station.

When a data transmission sequence error occurs in each slave station, the corresponding flag bit turns ON.

Station No	1	2	3	4	5	6	7	8	9	10	11	12	13	14	15
Relay	M8184	M8185	M8186	M8187	M8188	M8189	M8190	M8496	M8497	M8498	M8499	M8500	M8501	M8502	M8503

3. Link device

It is a device for sending and receiving information between programmable controllers. The device number and the number of points used differ depending on the station number set in the corresponding station number setting and the mode set in the refresh range setting.

1) Mode 0 (D8178=0):

Station No	Station 0	Station 1	Station 2	Station 3	Station 4	Station 5	Station 6	Station 7
Word device (4 points each)	D0~D3	D10~D13	D20~D23	D30~D33	D40~D43	D50~D53	D60~D63	D70~D73
Station No	Station 8	Station 9	Station 10	Station 11	Station 12	Station 13	Station 14	Station 15
Word device (4 points each)	D80~D83	D90~D93	D100~D103	D110~D113	D120~D123	D130~D133	D140~D143	D150~D153

2) Mode 1 (D8178=1):

Station No	Station 0	Station 1	Station 2	Station 3	Station 4	Station 5	Station 6	Station 7
Bit device (32 points each)	M1000 ~ M1031	M1064 ~ M1095	M1128 ~ M1159	M1192 ~ M1223	M1256 ~ M1287	M1320 ~ M1351	M1384 ~ M1415	M1448 ~ M1479
	D0~D3	D10~D13	D20~D23	D30~D33	D40~D43	D50~D53	D60~D63	D70~D73

Station No	Station 8	Station 9	Station 10	Station 11	Station 12	Station 13	Station 14	Station 15
Bit device (32 points each)	M1512 ~ M1543	M1576 ~ M1607	M1640 ~ M1671	M1704 ~ M1735	M1768 ~ M1799	M1832 ~ M1863	M1896 ~ M1927	M1960 ~ M1991
	D80~D83	D90~D93	D100~D103	D110~D113	D120~D123	D130~D133	D140~D143	D150~D153

3) Mode 2 (D8178=2):

Station No	Station 0	Station 1	Station 2	Station 3	Station 4	Station 5	Station 6	Station 7
Bit device (64 points each)	M1000 ~ M1063	M1064 ~ M1127	M1128 ~ M1191	M1192 ~ M1255	M1256 ~ M1319	M1320 ~ M1383	M1384 ~ M1447	M1448 ~ M1511
	D0~D7	D10~D17	D20~D27	D30~D37	D40~D47	D50~D57	D60~D67	D70~D77
Station No	Station 8	Station 9	Station 10	Station 11	Station 12	Station 13	Station 14	Station 15
Bit device (64 points each)	M1512 ~ M1575	M1576 ~ M1639	M1640 ~ M1703	M1704 ~ M1767	M1768 ~ M1831	M1832 ~ M1895	M1896 ~ M1959	M1960 ~ M2023
	D80~D87	D90~D97	D100~D107	D110~D117	D120~D127	D130~D137	D140~D147	D150~D157

8.5.2 Program setting and description

The program settings are as shown below. It is recommended to set the timeout wait register D8129/D8409/D8429 above 12. It is only necessary to set the corresponding special register to achieve the data sharing of the corresponding interval register and auxiliary relay. Channel M8184~M8190 and the rear 8 channels M8496~M8503, you can check the status of each slave, if there is no connection, turn ON

1. Serial port 2

Master program:

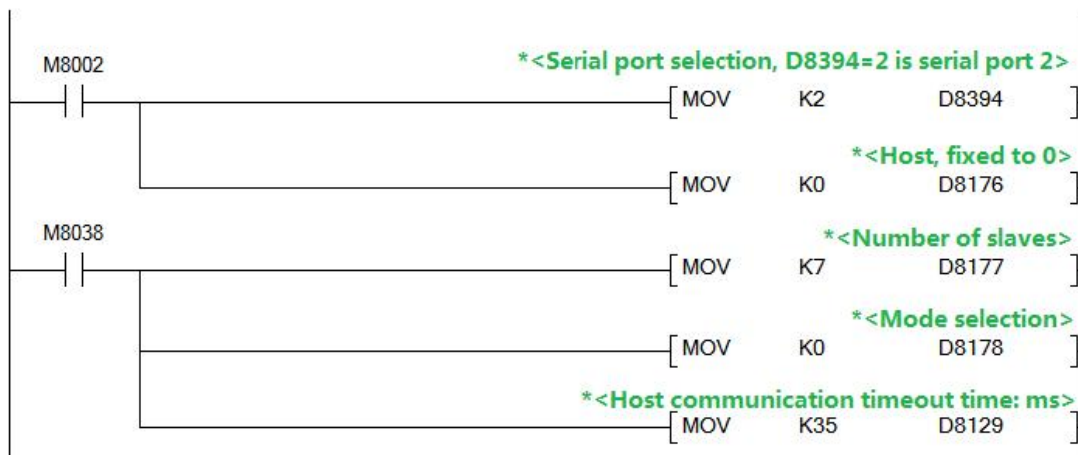

Slave program:

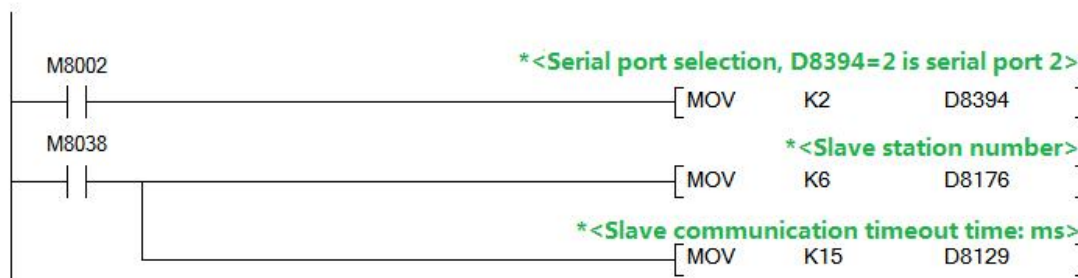

2. Serial port 3

Such as serial port 2, only need the master and slave program to set D8394=3

Appendix Version Change Record

Date	Changed version	Change content
Sep. 2022	V22.91	◆ First version released